

Chemical Synthesis of Oligonucleotides

V. AMARNATH and A. D. BROOM*

Department of Biopharmaceutical Sciences, College of Pharmacy, University of Utah, Salt Lake City, Utah 84112

Received January 9, 1976 (Revised Manuscript Received April 19, 1976)

Contents

I. Introduction	183
II. Statement of the Problem	183
III. Protecting Groups	184
A. Protection of the Carbohydrate Hydroxyl Functions	184
1. Protection of the 2'-Hydroxyl Group in Ribose	184
2. Protecting Groups for 5'- and/or 3'-Hydroxyl Functions	188
3. Simultaneous Protection of 2'- and 3'-Hydroxyl Functions	192
B. Phosphate Protecting Groups	194
1. Internucleotide Phosphate Protection	194
2. Protection of a Terminal Phosphate Group	195
C. Protection of the Amino Functions on the Bases	197
1. <i>N</i> -Dimethylaminomethylene Group	197
2. Acyl Groups	198
3. Isobutyloxycarbonyl Group	198
IV. Internucleotide Bond Formation	198
A. In Situ Activation of the Phosphate Function	198
B. Coupling through Elimination of HX (X ⁻ , a Good Leaving Group)	199
C. Through Cyclonucleosides	200
V. Synthesis	201
A. Nonspecific Phosphodiester Linkage	201
B. Chemical Polymerization	202
1. Polymerization with Condensing Agents	202
2. Use of Cyclonucleoside Phosphates	202
3. Catalyzed Polymerizations	202
4. Block Condensation	203
5. Polymerization on Templates	203
C. Stepwise Synthesis in Solution	204
1. Type 1 Condensations	204
2. Type 2 Condensations	205
D. Block Synthesis in Solution	208
1. Oligonucleotides with Terminal Phosphate Groups	208
2. Joining the Blocks	208
E. Synthesis on a Polymer Support	209
1. Preparation of the Polymer Supports	209
2. Ease of Handling	210
3. Attachment to and Removal from the Polymer Support	211
4. The Yield at the Coupling Step	211
VI. Conclusion	211
VII. Appendix	211
VIII. References and Notes	213

I. Introduction

Ribo- and deoxyribooligonucleotides are of interest both because of their biological significance and for the challenge they present to the synthetic organic chemist. The synthesis of oligonucleotides and their conversion to polynucleotides of known nucleotide sequence have made possible studies in the

genetic code,^{1,2} in decoding the nucleotide sequences in DNA regions controlling initiation and termination of transcription,³ in the action of DNA and RNA polymerases, and in structure-function relationships of *t*-RNA. Synthetic oligonucleotides containing the required codons have potential use in the enzymatic assembly of proteins which are difficult to prepare by other means.⁴ Further investigations on the biological functions of oligonucleotides and exploration of their potential pharmacological uses await efficient and convenient chemical synthesis of nucleotide chains having defined nucleotide sequences.

Since Khorana⁵ initiated the pioneering research (see ref 6–8 for earlier reviews) in this field, many synthetic routes involving various protective groups have been successfully undertaken. Synthesis of icosadeoxyribonucleotide segments during a total gene synthesis^{9,10} and of a nonaribonucleotide¹¹ can be considered as indications of progress made in the past few years.

Recently Khorana¹² and Ikehara¹³ published short accounts of their work in oligonucleotide synthesis. However, a comprehensive review covering all aspects of chemical synthesis of oligonucleotides is needed to present the developments of the past decade in the light of problems still to be solved. The present review is aimed at this goal, and papers cited in *Current Contents* up to September 1975 (Vol. 18, No. 39) have been included.^{14,15}

II. Statement of the Problem

The complexity of oligoribonucleotide synthesis may be illustrated by the reactions leading to the trinucleotide GpApU (Scheme 1).¹⁶ 5'-*O,N*-Diacetyl-2'-*O*-tetrahydropyran-2-yladenosine 3'-phosphate (**1**) and 2',3'-*O*-methoxymethylideneuridine (**2**) illustrate the protected monomers. Various methods for forming the internucleotide linkage between nucleoside residues are outlined in section IV. The tendency of the phosphodiester moiety to undergo 3' → 2' migration in **3** is eliminated by protection of the 2'-hydroxyl with, for example, a tetrahydropyranyl group. The 5'-*O*-acetyl and 2',3'-*O*-methoxymethylidene groups in **1** and **2**, respectively, are typically used to direct specific phosphodiester bond formation between the 3'-phosphate of the nucleotide **1** and 5'-hydroxyl of the nucleoside **2**. More will be said about such hydroxyl blocking agents in section III.A. Section III.C is devoted to a discussion of amino-protecting groups, such as acetyl, which preclude the possibility of *N*-phosphorylation of the amino functions of adenine, guanine, or cytosine.

The protected dinucleoside monophosphate **3** is treated with base in order to free the 5'-hydroxyl function (the *N*⁶-acetyl group is simultaneously hydrolyzed) in preparation for condensation with another nucleotide **6**. The amino function of **4** might be selectively protected by treatment with dimethylformamide dimethyl acetal. Coupling of **5** with the appropriately protected nucleotide **6** in the presence of TPS leads to **7**. Base treatment of the protected trinucleoside diphosphate **7** removes the acetyl and *N*-dimethylaminomethylidene groups; subsequent acid

SCHEME I

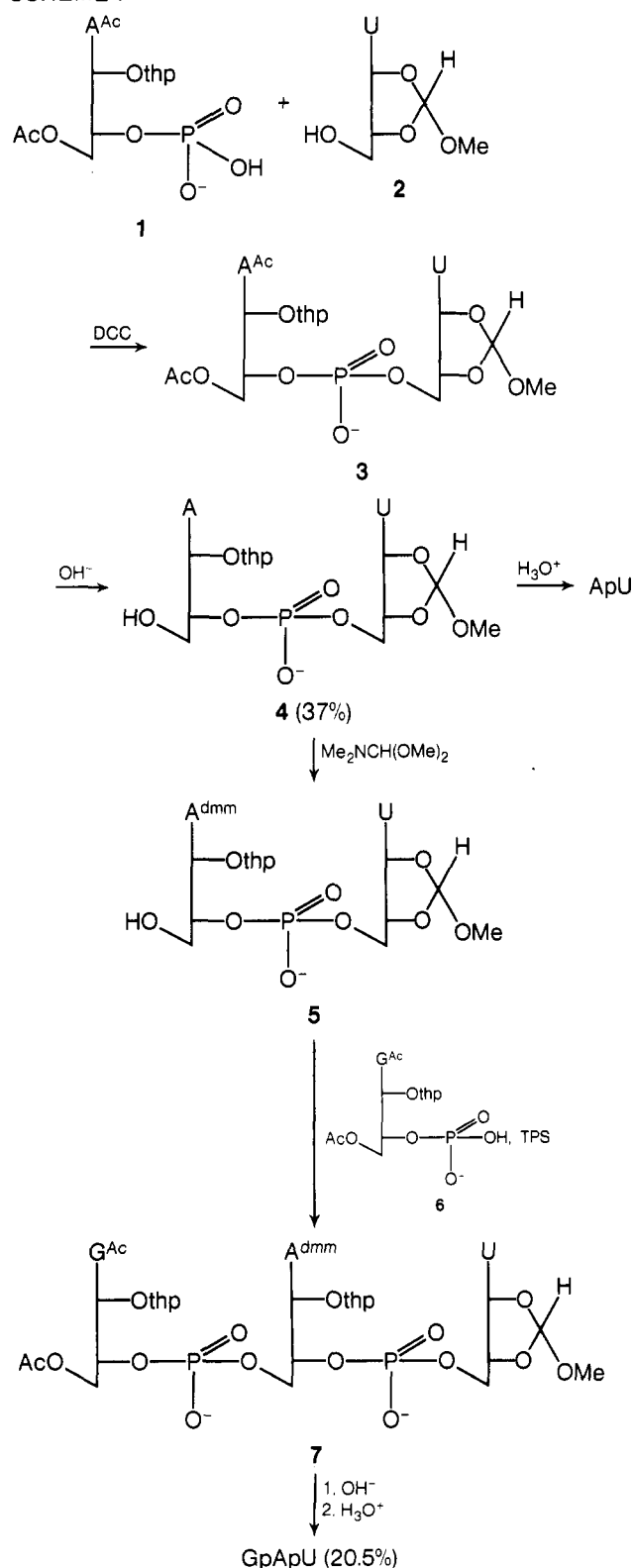

treatment hydrolyzes the tetrahydropyranyl and methoxymethylidene groups yielding, in this case, guanylyl(3'-5')-adenylyl(3'-5')-uridine.

If the final oligonucleotide should bear a terminal phosphate, one usually starts with a nucleotide in place of the nucleoside component, such as **2**. Such a nucleotide, in addition to the protective groups mentioned earlier, must also carry a blocking agent on the phosphate to prevent the latter from reacting with an available hydroxyl function (section III.B).

Stepwise synthesis as outlined in Scheme I, chemical polymerization of nucleotides, synthesis of oligonucleotides on

SCHEME II

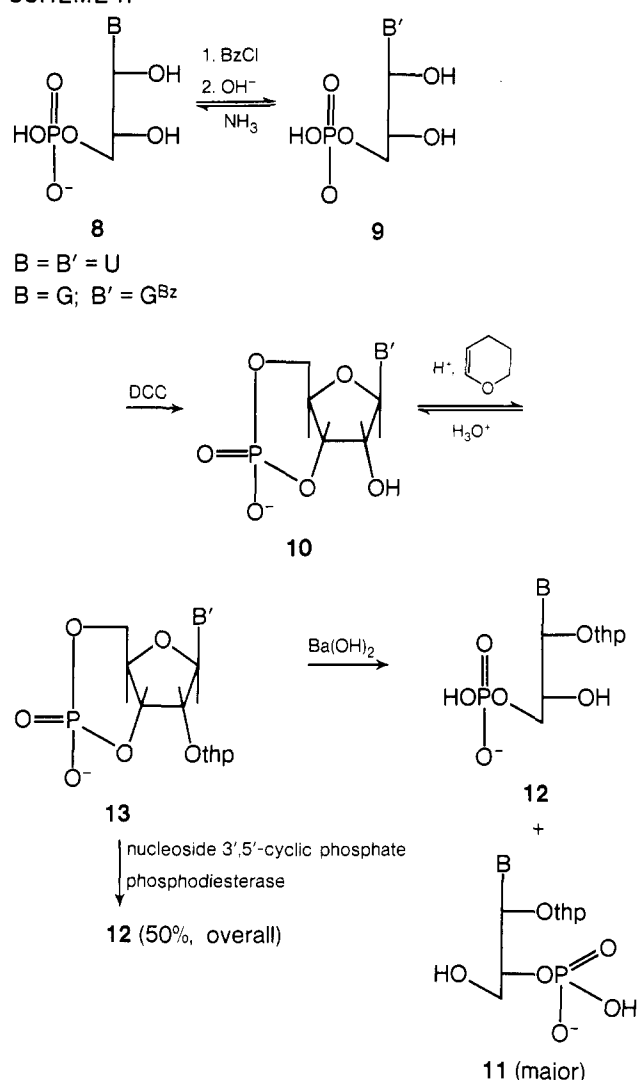

polymer supports, and related synthetic reactions are all discussed in section V.

III. Protecting Groups

A. Protection of the Carbohydrate Hydroxyl Functions

Protecting groups for the hydroxyl functions on ribose and deoxyribose play a very important role in the synthesis of oligonucleotides. The value of a particular blocking agent depends on the following four main factors: (1) the ease and specificity of attachment of the protecting group to the desired hydroxyl function, (2) the stability of the group to the conditions required for internucleotide bond formation, (3) the ease of deblocking under conditions which prohibit 3' \rightarrow 2' phosphate migration, and (4) the yields of the blocking and deblocking reactions. The available protecting groups will be discussed under three headings according to the positions of the hydroxyl functions they protect.

1. Protection of the 2'-Hydroxyl Group in Ribose

The lack of an ideal protecting group for the 2'-hydroxyl function has caused considerable delay in the progress of synthesis of oligoribonucleotides as compared to deoxyoligoribonucleotides. The best masking group for this purpose would be one which is stable to conditions required for the chain elongation and for the attachment and release of other protecting groups, thereby preventing the isomerization of 3'-5' phos-

phodiester to the 2'-5' linkage, and which may be cleaved usually as the last step without affecting other bonds and groups. At present, practically all methods for introducing the masking groups on 2'-hydroxyl function also lead to 3' isomers and hence necessitate separation of 2' and 3' derivatives.

a. Acid Labile Groups

i. Trityl Group. The trityl group has found some use in blocking the 2'-hydroxyl as illustrated by the well-known 2',5'-di-*O*-trityluridine.¹⁷ However, the steric bulk of the trityl group markedly reduced the yield of condensation reaction in the synthesis of uridylyridine¹⁸ compared to reactions in which a smaller 2'-hydroxyl protecting group was used. For this reason, the trityl function is reserved almost exclusively for protection of the 5'-hydroxyl moiety (*vide infra*).

ii. The Tetrahydropyran-2-yl Group. This group was initially evaluated for the protection of the 2'-alcoholic function because of the ease of its introduction with 2,3-dihydro-4*H*-pyran and its lability under mild acidic conditions. The original method of Khorana^{19,20} and Fresno²¹ for the preparation of 2'-*O*-tetrahydropyranyl acetals of nucleotides is outlined in Scheme II.

A satisfactory chemical synthesis was later provided by Reese²² and extended by Neilson and Werstiuk.^{23,24} Cleavage of the 2',3'-*O*-cyclic orthoacetate **16** with acid gave a mixture of 2'- and 3'-acetates **17** and **18**^{25,26} in varying ratios (3':2', 3:1

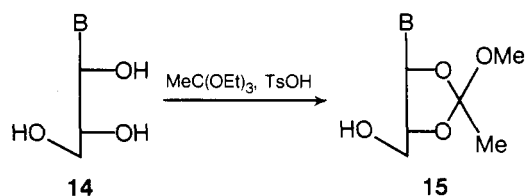

B = *N*-benzoyl C, A, or G

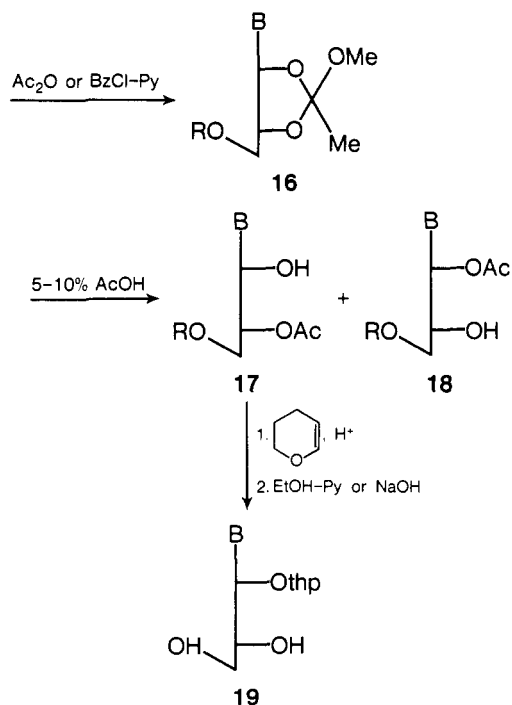

for cytidine²³ and 1:1 for guanosine²⁴). The 3'-acetate **17**, which was usually less soluble than the 2' isomer, was purified by fractional crystallization from ethanol and allowed to react with 2,3-dihydro-4*H*-pyran; release of the acyl moieties on 3' and 5' positions under mildly basic conditions yielded the target compound **19**. The overall yields of the 2'-*O*-tetrahydropyranyl nucleosides ranged from 5 to 15%. Dilute acetic acid, 0.01 N hy-

drochloric acid,²² or sulfonic acid resins in the pyridinium or ammonium form²⁷ suffice for complete hydrolysis of this acetal group.

Unfortunately from synthetic point of view, the reaction of 2,3-dihydro-4*H*-pyran with an asymmetric nucleoside gives rise to a pair of diastereomers (**20** and **21**) in a ratio which is deter-

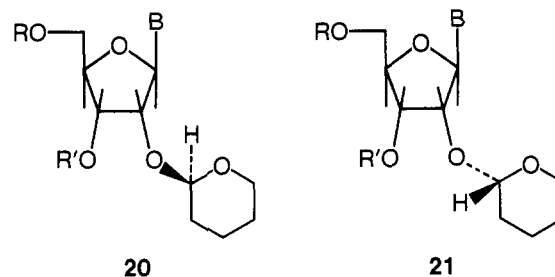

mined in an unpredictable manner by asymmetric induction. The component with lower *R_f* value on silica gel and with higher melting point is usually more readily isolated and is therefore selected for further reactions.^{23,24} In addition to the obvious reduction in yield (by 30-50% depending on the particular nucleoside) inherent in the selection of only one isomer, a tedious separation procedure is required in order to obtain the pure, crystalline, blocked nucleoside.

Neilson and his co-workers¹¹ have successfully used the tetrahydropyran moiety for protection of 2'-hydroxyl functions in their synthesis of the anticodon loop of *E. coli* methionine *t*-RNA.

iii. 4-Methoxytetrahydropyran-4-yl Group. As an alternative to the asymmetric and hence troublesome tetrahydropyran-2-yl group, Reese²⁸ introduced the symmetrical 4-methoxytetrahydropyran-4-yl ketal function. The required reagent, 4-methoxy-5,6-dihydro-2*H*-pyran (**24**), was prepared by heating tetrahydro-4*H*-pyran-4-one dimethyl ketal with a trace of mesitylenesulfonic acid.²⁹ The preparative pathway to the 2'-*O*-(4-methoxytetrahydropyran-4-yl)nucleoside is very similar to that

SCHEME III

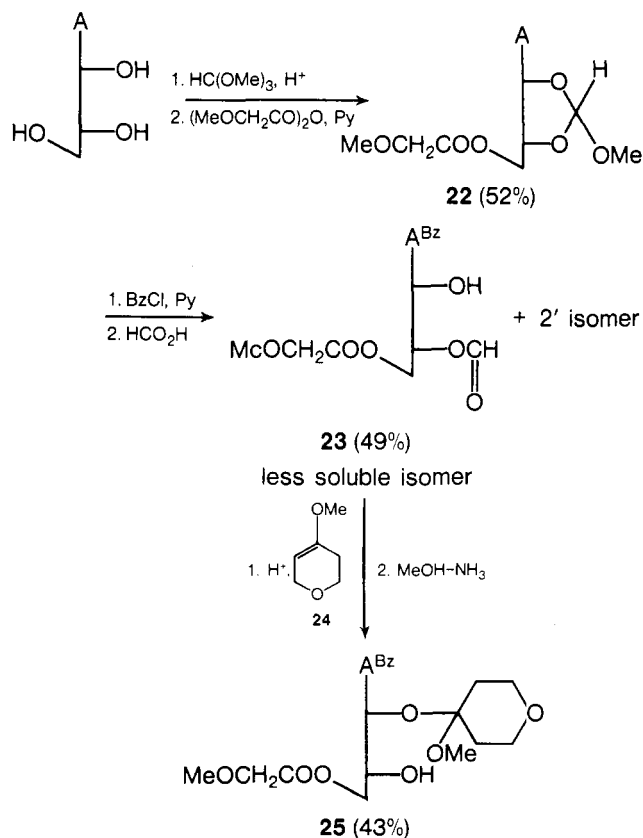

of the 2'-*O*-tetrahydropyranyl derivatives as illustrated for the synthesis of **25** in Scheme III.³⁰ The 4-methoxytetrahydropyranyl, which was found to be more acid labile than tetrahydropyranyl,²⁹ was successfully utilized by Reese³¹ in the synthesis of short-chain oligoribonucleotides.

iv. Other Groups. Recently Reese³² introduced two more achiral groups **26** and **27** for the protection of hydroxyl functions. The thioether ketal **26** was slightly more labile and the sulfone

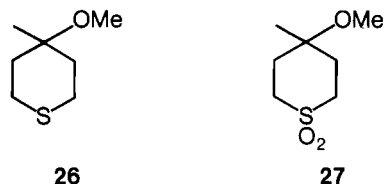

ketal **27** much less labile than the oxygen analog toward acidic hydrolysis. The different rates of hydrolysis seem to be dictated by the basicities of the ether, thioether, and sulfone groupings compared to the basicity of the ketal oxygen.

Other ketal functions such as 1-ethoxyethyl,³³⁻³⁵ 2-methoxy-2-propyl,²⁸ and various alkyl groups³⁶ (introduced in a manner similar to that of Scheme II) have been considered. These groups offer no advantage to those described above and have not assumed a significant role in ribonucleoside protection.

b. Base Labile Groups

The only base labile 2'-hydroxyl protecting groups studied to date have been acyl groups. These share the important disadvantage that migration of a 2'-*O*-acyl group to an unprotected 3'-hydroxyl is a facile reaction. Also monoacylation of 5'-*O*-substituted nucleosides generally leads to a mixture of both isomers.³⁷ Since the 3' isomer **29** is marginally more stable than

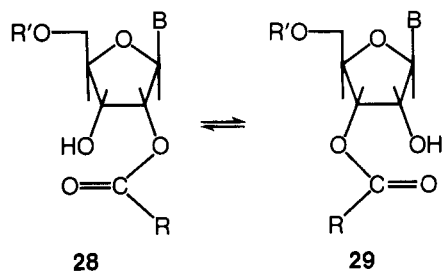

the 2' isomer **28** in most cases so far investigated, the use of acyl groups for the purpose of masking the 2'-hydroxyl was not considered profitable in the early studies.³⁸ Equilibration is slow in anhydrous pyridine, but very fast in aqueous solutions around pH 7.^{39,40} However, the rate of isomerization varies considerably with the nature of the acyl group. For example, in anhydrous pyridine the relative mobilities of *p*-anisoyl, benzoyl, acetyl, and formyl moieties are respectively 1, 1.5, 27, and 1000.^{39,41} The base also exerts some influence; adenosine derivatives are isomerized slightly faster than derivatives of uridine.^{39,40} The effect of the base may well be an indirect one resulting from the well-known but poorly understood influence of the base upon the conformation of the sugar.⁴²

Less mobile acyl groups hold promise as masking groups for the 2'- or 3'-hydroxyl functions. The most useful approach to monoacylation of the *cis*-glycol system in ribonucleosides relies upon the readily prepared 2',3'-*O*-alkoxyalkylidene derivatives. Upon mild acid hydrolysis, these compounds yield a mixture of 2'- and 3'-*O*-acylribonucleosides. Unfortunately, the 3' isomer usually predominates, and the separation procedures are somewhat laborious.⁴³

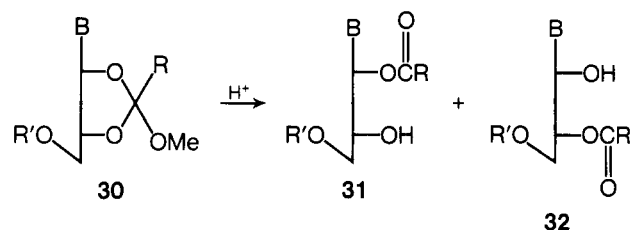

	R	R'	B	Yield of 31 , %
a	Me	Pv	CPv	29
b	Ph	Bz	GBz	16
c	MeOCH ₂	An	A ^{An}	70

The acyl group is usually stable to a wide range of reaction conditions involving acidic or neutral solutions and is removed

SCHEME IV

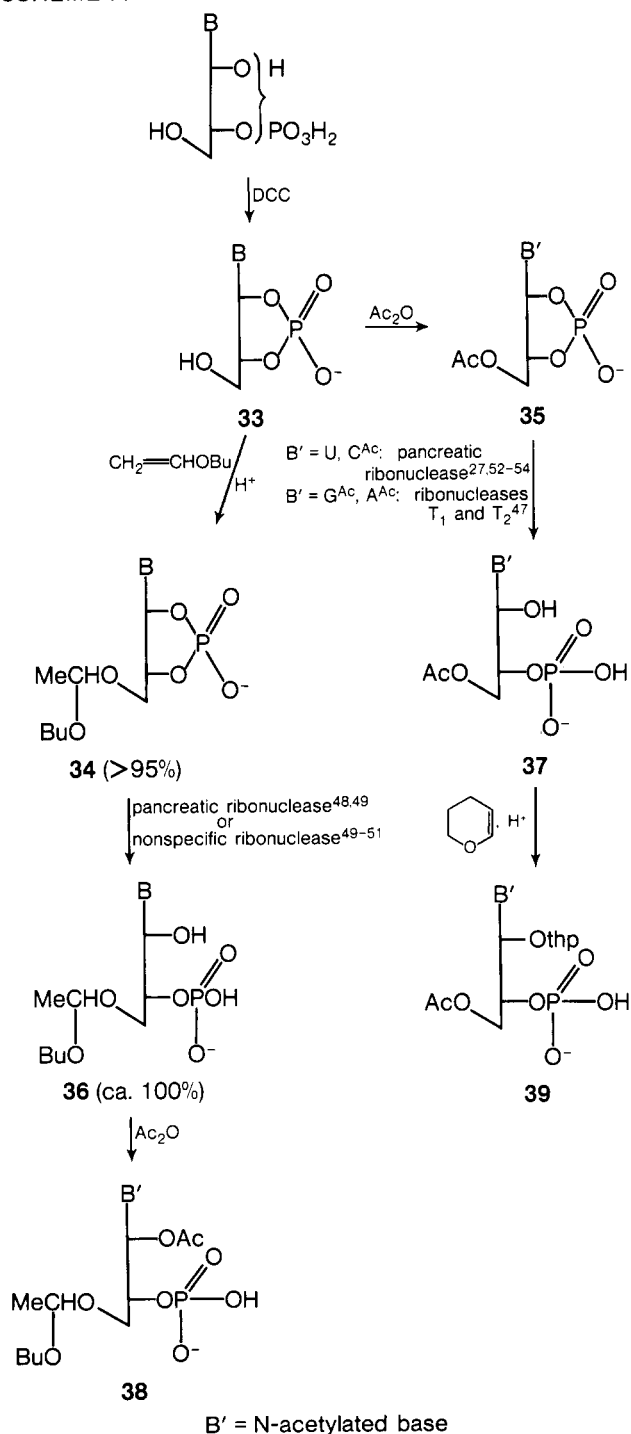

by alcoholic methylamine.⁴¹ The benzoyl group has been used by Ikehara et al.⁴⁴ for blocking the 2'-hydroxyl function in their synthesis of short oligoribonucleotide chains. Since the rate of removal of an acyl group under basic conditions is proportional to its negative inductive effect,⁴⁵ other groups such as methoxyacetyl,³⁰ chloroacetyl, and formyl⁴⁶ have also been occasionally used.

An often-needed component in oligoribonucleotide synthesis is a 3'-nucleotide bearing substituents at the 5' and 2' sites which are selectively removable under different conditions (**38** and **39**). Scheme IV illustrates two combined chemical and enzymatic approaches to such key intermediates.^{27,47-54} Similar procedures have been applied to a dinucleotide 2',3'-O-cyclic phosphate for the trinucleotide synthesis.⁵⁵

c. Groups Removable under Neutral Conditions

Purine-glycosyl bonds of nucleosides and nucleotides, particularly when the purine bears an N-acyl group, may be partially broken under the acidic conditions necessary to remove acid-susceptible blocking groups.⁵⁶ This points to the consideration of protective groups removable under neutral conditions. Since removal of the 2'-hydroxyl protecting group is usually the ultimate step in a synthetic sequence, the availability of both acid and base labile groups for 3'- and 5'-hydroxyl protection suggests that a blocking agent for 2'-hydroxyl function insensitive to acidic and basic conditions would be advantageous.

i. Benzyl Group. Cleavage of benzyl ethers by catalytic hydrogenolysis to toluene and an alcohol is a well-known phenomenon which has led a number of investigators^{20,57-64} to undertake the preparation of 2'-O-benzylribonucleosides. Reese and his coworkers,⁵⁸ for example, were able to cleave the benzyl group under neutral conditions from **40** to obtain UpU.

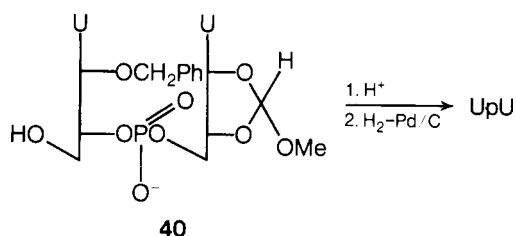

A careful evaluation of the benzyl moiety in oligonucleotide synthesis was delayed by the difficulties encountered in the preparation of pure 2'-O-benzylribonucleosides. For example, benzylation of uridine⁵⁹ or cytidine⁶⁰ with benzyl bromide and sodium hydride gave, in addition to the reaction at the 2' position, N-benylation of the pyrimidine **41**. Thus prior protection of sites

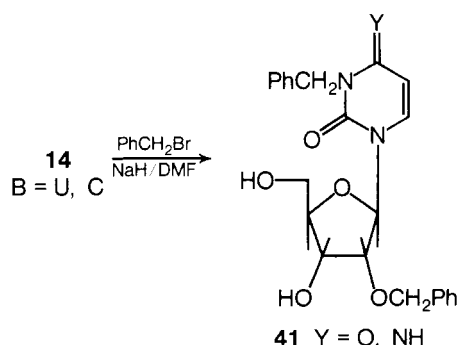

on the nucleoside susceptible to alkylation, as illustrated by **42** and **44**,⁶¹ was necessary to reduce the number of undesired products. Recently, however, a one-step procedure for the preparation of a readily separable mixture of 2'- and 3'-O-benzyl ribonucleosides was reported.⁶⁴ Reaction of the unprotected nucleoside with phenyldiazomethane in the presence of a

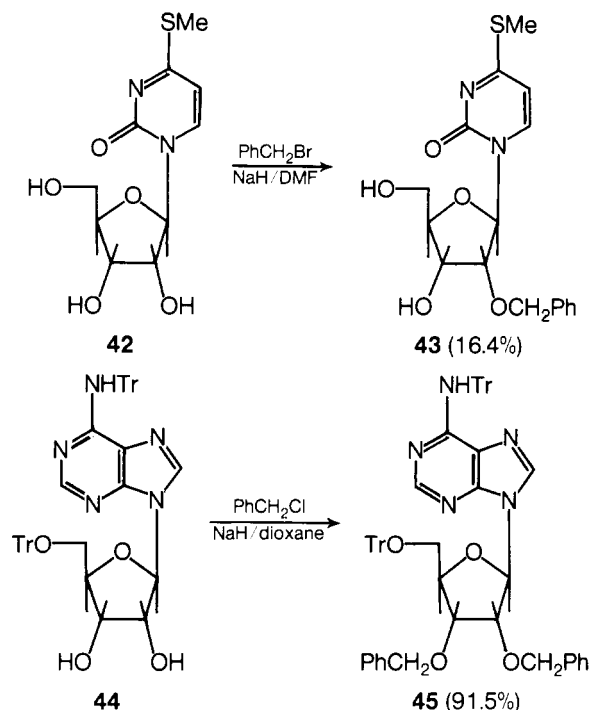

stannous chloride catalyst readily afforded **46** and **47** in reasonable yields. Some difficulty was encountered in hydrogenolytic deblocking of the pyrimidine derivatives (especially cytidine); concomitant reduction of the 5,6 double bond occurred to some extent, suggesting the benzyl ethers may not be as useful⁶⁵ as originally hoped.

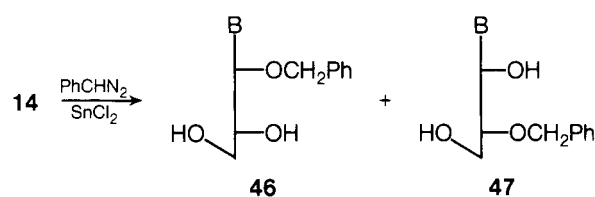

B	Yield, %	Yield, %
	46	47
A	27	38.5
I	21	14
G	16	18
U	20.3	14.5
C	34	19

ii. o-Nitrobenzyl Group. *o*-Nitrobenzyl derivatives have found use as photosensitive protecting groups for amino acids^{66,67} and carbohydrates.^{68,69} The protected compound **48**, on irradiation

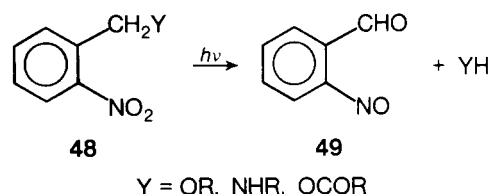

in a variety of protic and nonprotic solvents at wavelengths longer than 320 nm, undergoes rearrangement leading to *o*-nitrosobenzaldehyde and the free alcohol or amine. This group, which is stable to acidic and basic conditions and which may be removed in neutral solution, is ideally suited for 2'-hydroxyl protection, and attention has been recently directed to this end.

Two successful attempts to prepare 2'-O-(*o*-nitrobenzyl) ethers of nucleosides have been reported. The first^{70,71} involves the action of *o*-nitrophenyldiazomethane on unprotected nucleosides; the total yields of 2' and 3' isomers were more than 80%. In the second approach⁷² 2'- and 3'-hydroxyl functions of uridine were selectively activated by formation of the 2',3'-O-(dibutylstannylene) derivative **52**⁷³ prior to treatment with

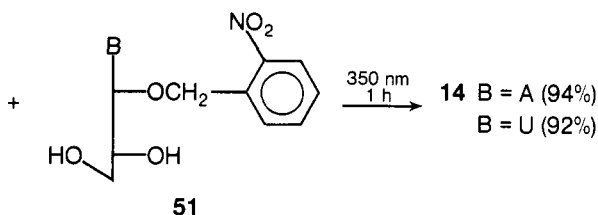
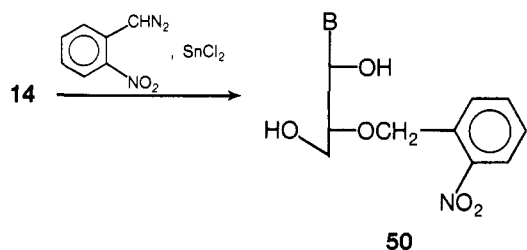

B	Yield of 51 , %
A	46
I	37
C	37
U	37

o-nitrobenzyl bromide. Only the 2' isomer was isolated in a yield of 24%. Deblocking of **51** and **54** in high yields was achieved by photolysis at 350 nm within 1 h.

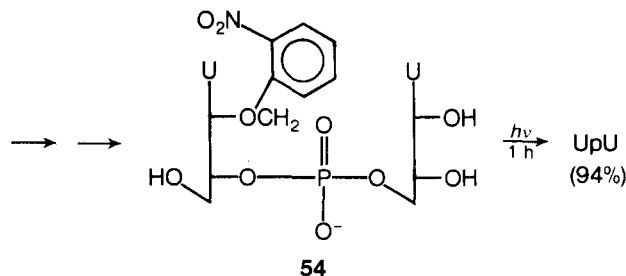
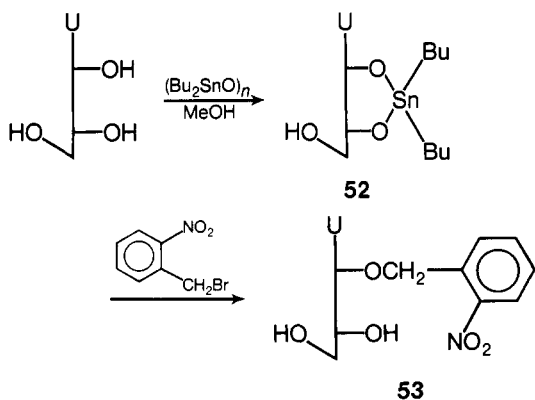

iii. *1-Oxido-2-picoyl Group*. 1-Oxido-2-picoyl⁷⁰ and 3-methyl-1-oxido-2-picoyl^{74,75} moieties have been recently examined as 2'-hydroxyl blocking agents. Photolytic deprotection of 2'-O-(1-oxido-2-pyridylmethyl)adenosine gave adenosine in only 55% yield;⁷⁰ treatment with acetic anhydride gave better yields^{70,75} but led to the formation of fully acetylated nucleosides.

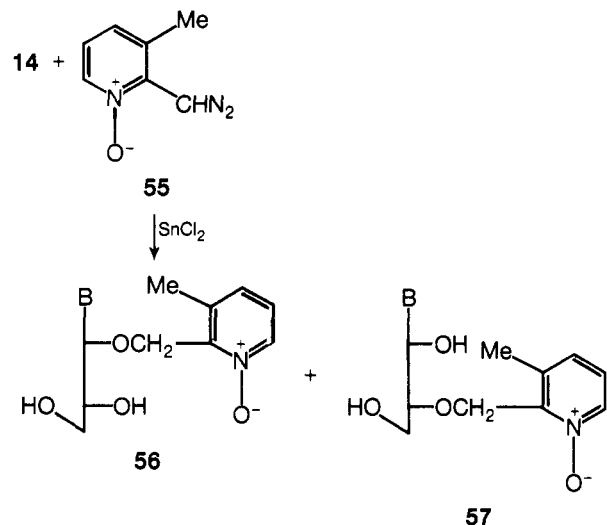

B	Yield, %
U	25 ..
A	34 13

2. Protecting Groups for 5'- and/or 3'-Hydroxyl Functions

Stepwise elongation of an oligonucleotide chain may, in principle, be carried out by any of the four approaches illustrated diagrammatically by pathways A–D. A comparative discussion of these strategies is reserved for section V; suffice it to say here that blocking groups represented by R^1 remain intact until removed from the final oligonucleotide product, whereas groups R^2 must be selectively removable prior to each chain elongation step. Selectivity in protection of the 5'-hydroxyl (a primary alcohol) is rather readily achieved using mild conditions and bulky blocking groups. Such selectivity is more difficult to obtain in masking the secondary 3'-alcohol function, particularly when it occurs as part of the *cis*-glycol moiety in ribonucleosides, and multiple step procedures are usually required for the preparation of compounds of the types **59** and **62** ($\text{R} = \text{OR}^3$).

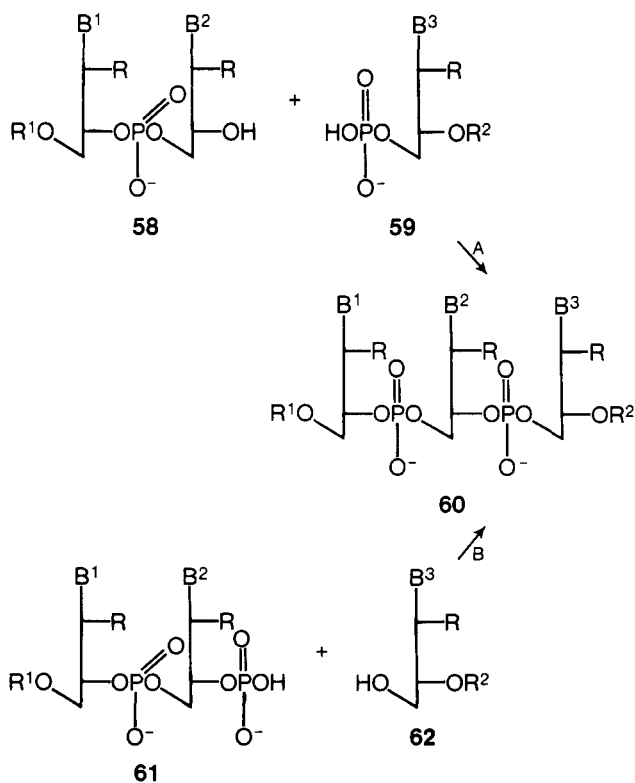

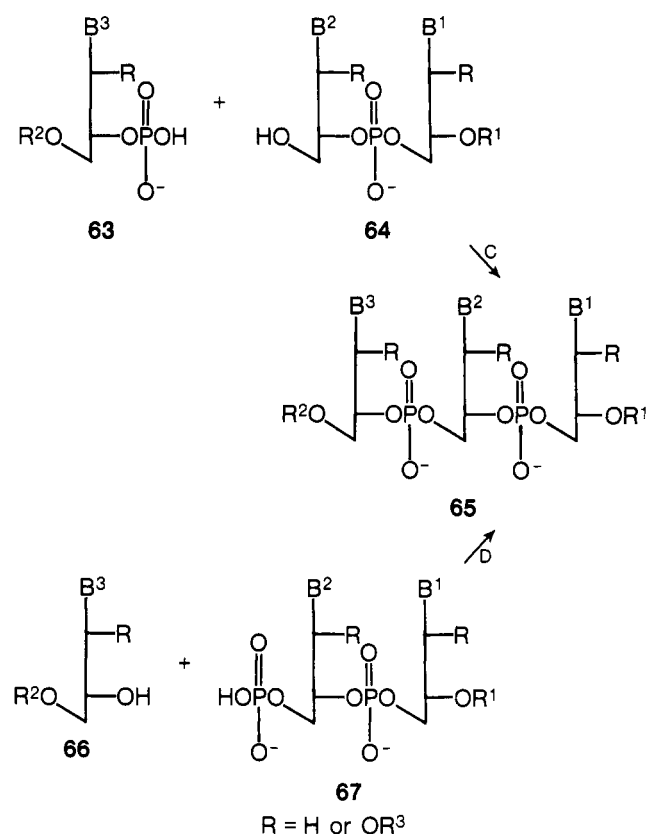

a. Acid Labile Groups

i. Trityl, Monomethoxytrityl, and Dimethoxytrityl Groups. Triphenylmethyl chloride derivatives^{20,56} are the most commonly used blocking agents for the 5'-hydroxyl function because alkylation takes place preferentially at the less hindered site. Secondary alcohol groups at 3' and 2' positions may also react to a slight extent;⁷⁶⁻⁷⁸ under forcing conditions, separable mixtures of 2',5'- and 3',5'-di-*O*-trityl-purine⁶¹ and -pyrimidine^{58,63} nucleosides are formed. Trityl chlorides bearing methoxy substituents in the para positions of one or more benzene rings are more reactive than trityl chloride and are slightly less selective for primary hydroxyls.²⁰ Acidic conditions necessary to hydrolyze

the unsubstituted trityl group may be severe enough to cause marked isomerization of the phosphodiester bond in the ribose series and cleavage of the glycosidic linkage in the 2'-deoxy series. Substitution of electron-releasing groups in the para position of the benzene rings should enhance acidic hydrolysis through stabilization of the incipient carbocation. This reasoning led Khorana^{20,38,56,79-81} to the synthesis of trityl derivatives carrying one, two, or three *p*-methoxy substituents. For each *p*-methoxy moiety introduced the acid lability of the tritylated compounds was found²⁰ to increase by a factor of 10. Monomethoxytrityl chloride, the ethers of which are readily cleaved at room temperature in pyridine-acetic acid buffer,⁸² by 80% acetic acid or by naphthalene radical ion in hexamethylphosphoric triamide,⁸³ exhibits the most optimal properties of stability and lability and hence the reagent of choice for 5' protection. Other derivatives of trityl group have also been proposed⁸⁴ but appear to offer little advantage over the monomethoxytrityl group.

Two additional advantages accrue with the use of trityl groups. First, their presence on the plates is readily detected by means of a ceric sulfate spray. Heating the sprayed chromatogram at 300-400 °C gives rise to a distinctive yellow-orange color denoting the location of trityl derivatives.⁸⁵ Second, the presence of bulky trityl groups on nucleotide chains renders them lipophilic, enabling Khorana's group⁸⁶ to separate tritylated compounds from others on trityl- and α -naphthylcarbamoylcellulose columns (Scheme V). Since the method is simple and the recovery almost quantitative, it is an efficient purification step preceding the separation of individual trityl derivatives.

ii. Acetal and Ketal Derivatives. Acid-labile 1-ethoxyethyl⁸⁷ and 1-butoxyethyl^{48,50,51} acetals, 4-methoxytetrahydropyran-4-yl and 2-methoxy-2-propyl⁸⁸ ketals, and semiacetal-semithioacetal derivative **72** have been considered for use as protecting groups for 5'- or 3'-hydroxyl functions. However, these moieties, particularly 4-methoxytetrahydropyran-4-yl^{31,89} and 1-ethoxyethyl,⁹⁰ are most useful when 2' and 5' sites are to be protected and

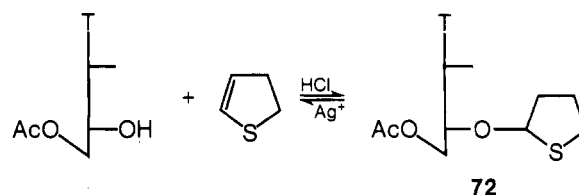

SCHEME V

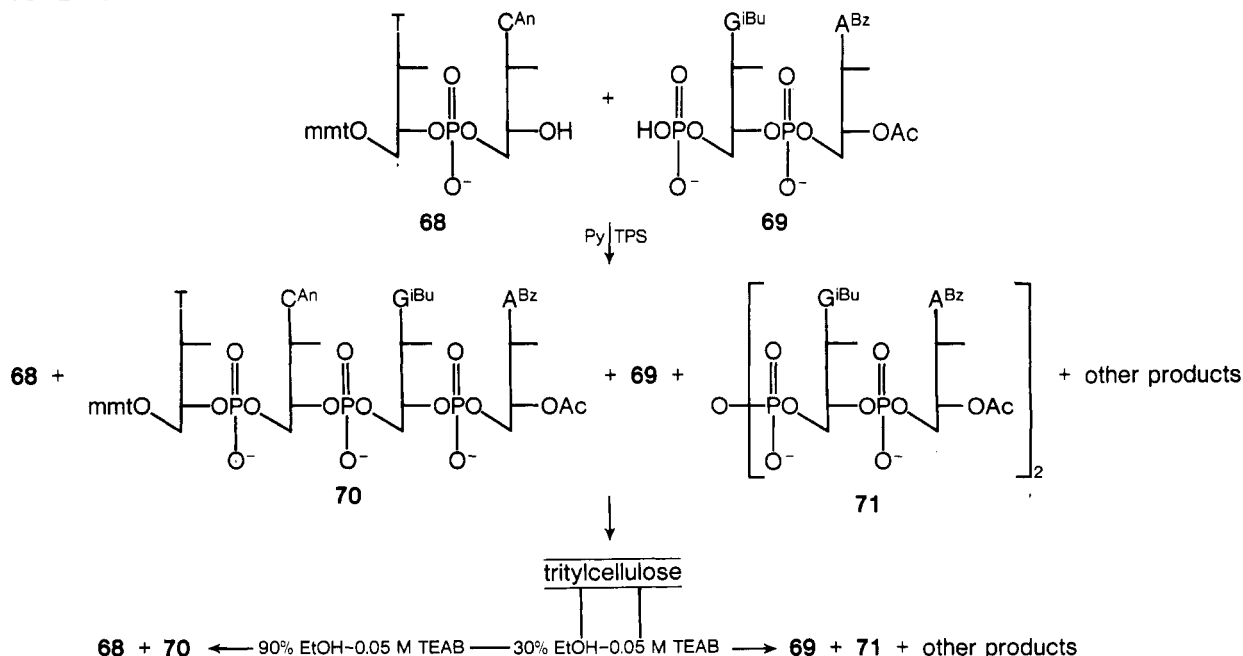

released simultaneously. For example, Reese and co-workers^{31,89} prepared the bisketal **73** and used it in the preparation of the dinucleotide phosphate **74** in good yield. 2',5'-Bisacetals

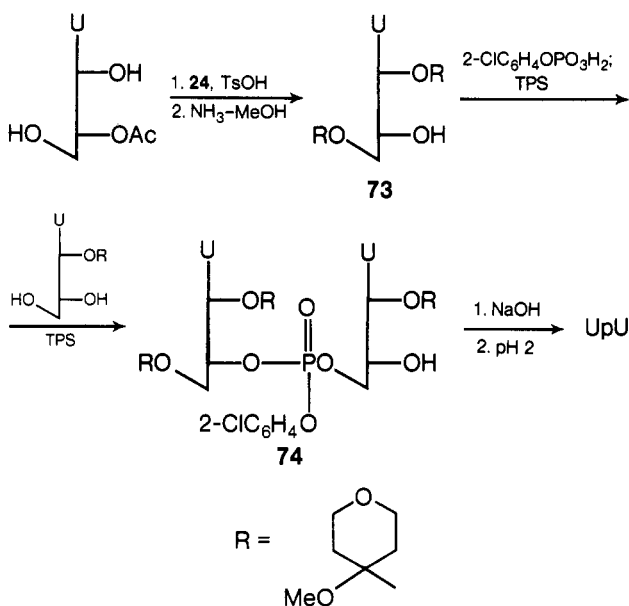

of uridine and uridine 3'-phosphate have also been obtained by treatment with a mixture of an aldehyde and alcohol in the presence of trifluoroacetic acid.^{48,91}

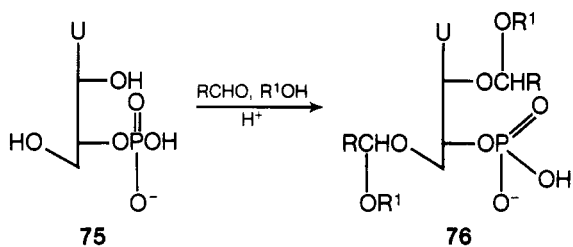

b. Base Labile Groups: Esters

Esters have been commonly employed for the protection of 3'- and/or 5'-hydroxyls; in the ribose series the 2'-hydroxyl is usually protected prior to acylation in order to eliminate 3' → 2' isomerization. Acylation is commonly accomplished by treatment of the nucleoside or nucleotide with an acyl chloride or anhydride in anhydrous pyridine;⁹²⁻⁹⁴ other reagents such as benzoyl cyanide⁹⁵ have also been occasionally used. It should be noted that free amino functions on the base moiety are often N-acylated under these conditions;⁷⁹ indeed this method is frequently used to protect the amino groups. Some selectivity for the 5' position has been demonstrated with bulky acyl chlorides such as pivaloyl chloride. An application of the pivaloyl group to the synthesis of **78** is illustrated in Scheme VI.

A unique access to selective 5'-O-benzoylation was recently achieved through the use of benzoic acid, diethyl azodicarboxylate, and triphenylphosphine.⁹⁶ An interesting approach combining the steric bulk of the trityl function with the base lability of an ester has been realized in the TPS-activated condensation of sodium triphenylmethoxyacetate with N,2'-O-protected ribonucleosides. The key intermediate **79** was obtained in more than 70% yield.^{97,98} The majority of other acylating agents show little selectivity for the 5' position. Methanolic ammonia and to a lesser extent sodium methoxide in methanol are used for breaking the ester linkage. Extended dissolution in TEAB buffer (pH 7.5) or short treatment with alkaline hydroxylamine solution have also been suggested.⁹⁹

The formyl group, the simplest acyl moiety, is one of the most susceptible to 3' → 2' migration.³⁹ Although earlier workers had

SCHEME VI

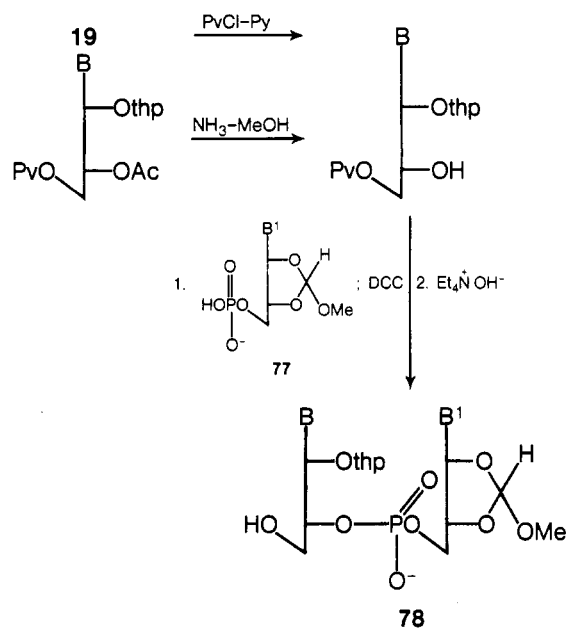

% yield of **78** based on **77**

B = B' = U	78
B = A; B' = U	58
B = U; B' = A	61

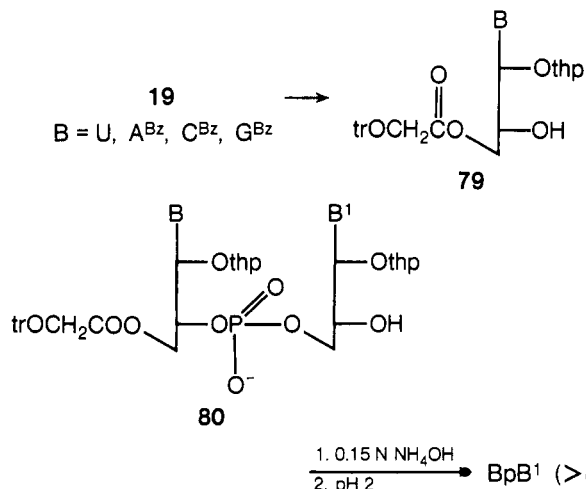

only limited success with the formyl group,^{43,46,100} Seliger¹⁰¹ has very recently resurrected it for protection of the 3'-hydroxyl function in the synthesis of 2'-deoxyribooligonucleotides. The acetyl moiety is widely used in oligonucleotide chemistry. A number of investigators^{53,102-104} have used 5'-O-acetyl-3'-nucleotides for dinucleotide synthesis, and Holy¹⁶ has prepared 37 trinucleotides in the same manner. The acetyl group has been extensively employed by Khorana¹² for masking the 3'-hydroxyl function.

Many substituted acetyl groups have been investigated in attempts to increase susceptibility to mild basic condition, including trifluoroacetyl,¹⁰⁵ phenoxyacetyl,¹⁰⁶ *p*-chlorophenoxyacetyl,¹⁰⁷ and methoxyacetyl¹⁰⁶ moieties. Of these, the methoxyacetyl group, which could be selectively removed by a solution of 0.2 N ammonium hydroxide in methanol,¹⁰⁶ was found¹⁰⁸ to be particularly suited for masking the 3' position. 3'-Methoxyacetyl derivatives are readily prepared by partial hydrolysis of orthoesters (for example, **30c**).

Scheme VII illustrates the application of *p*-nitrophenyl chloroformate to 5'- or 3'-hydroxyl protection,¹⁰⁴ although poor selectivity mediates against its general use for the former. Cleavage of the *p*-nitrophenyloxycarbonyl residue was brought

SCHEME VII

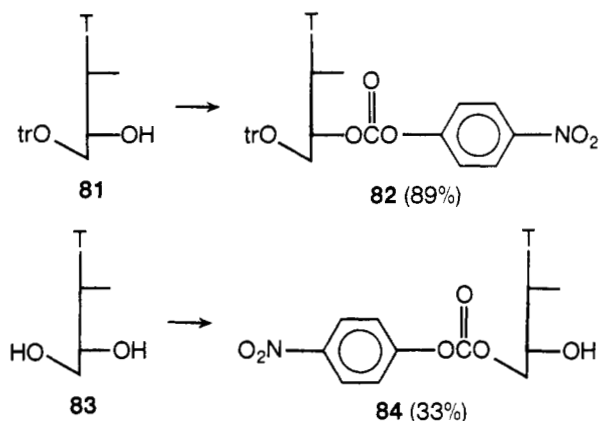

about by imidazole in aqueous organic solvents under weakly basic conditions.

c. Groups Removable in Neutral Solutions

i. Chloroacetyl Group. Chloroacetic anhydride, which lacks selectivity, was found¹⁰⁹ to esterify partially protected thymidine, giving the corresponding chloroacetyl derivatives. Diphenylchloroacetyl chloride exhibited selectivity toward the primary alcohol function of thymidine. The reagents evaluated for selective removal of chloroacetyl group include thiourea in ethanol,¹¹⁰ 2-mercaptoethylamine, ethylenediamine, and *o*-phenylenediamine.¹⁰⁹

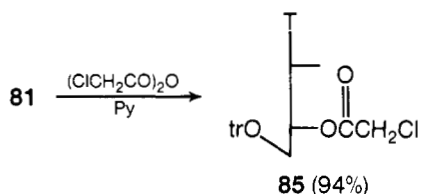

ii. 2,4-Dinitrobenzenesulfonyl Group. This moiety was studied by Letsinger,¹¹¹ who found it to be removable cleanly from the 5'-hydroxyl site of nucleosides by thiophenol in phenol.^{111,112} The reaction of adenosine or its N⁶-acyl derivative with 2,4-dinitrobenzenesulfonyl chloride is not selective, giving a mixture of products in low yield.^{112,113} Also the protection in 5'-*O*-(2,4-dinitrobenzenesulfonyl)-2'-*O*-tetrahydropyranlyridine was not complete under conditions of phosphorylation involving 2,2,2-trichloroethyl phosphate and TPS in pyridine.⁹⁷

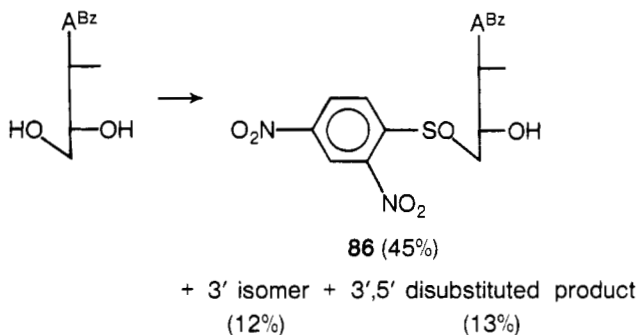

iii. Benzoylpropanoyl Group. Letsinger^{114,115} introduced the benzoylpropanoyl derivatives as very effective 3'-hydroxyl blocking agents in oligonucleotide synthesis. Deprotection was effected with dilute hydrazine hydrate solution (0.5 M) in pyridine-acetic acid buffer; the ester moiety was lost as 4,5-dihydro-6-phenylpyridazine leaving both acid and base sensitive linkages unaffected. Letsinger was able to prepare hexathymidylic acid in 11% yield using 3'-*O*-benzoylpropanoylthymidine as the building unit.¹¹⁶

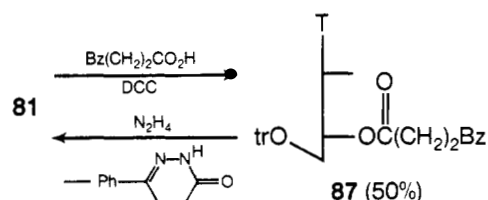

iv. 2,2,2-Tribromoethyl Chloroformate. A protecting group which is stable to acid but may be removed via a β -elimination promoted by a zinc-copper couple is 2,2,2-tribromoethoxycarbonyl.¹¹⁷ Chloroformate **88** reacted at 0 °C with the hydroxyl functions of thymidine within 1 h. In the case of 2',3'-*O*-isopropylideneadenosine, prior protection of the amino group was found necessary to avoid N-substitution.

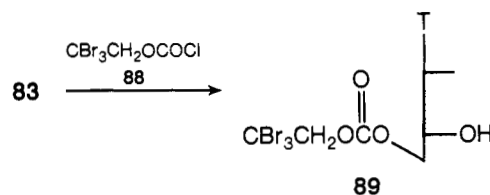

v. Silyl Groups. Trimethylsilyl derivatives of nucleosides and nucleotides were initially prepared in order to render these highly polar, high-melting compounds sufficiently volatile for gas-liquid chromatography.^{118,119} The stable *tert*-butyldimethylsilyl protective group introduced by Corey¹²⁰ has enhanced the utility of silyl groups as hydroxyl masking agents. Ogilvie^{121,122} evaluated various silyl chlorides for blocking hydroxyl functions of the nucleosides. Generally silyl derivatives are stable to base and hydrazine hydrate, conditions usually employed for the removal of acyl-protecting groups. They are deblocked easily by treating with tetrabutylammonium fluoride in tetrahydrofuran. In addition, mass spectroscopy can be used to identify silylated nucleosides and nucleotides.¹²³

Ogilvie¹²⁴ reported that in the 2'-deoxy series, *tert*-butyldimethylsilyl and, in particular, tri(isopropyl)silyl and tetramethylene-*tert*-butylsilyl chlorides showed preference for the 5'-hydroxyl function over 3'-hydroxyl in forming the monosubstituted derivative. The 5'-*O*-silyl ethers, in turn, were found to be more acid labile than the 3' isomers.

In the case of uridine the trend in reactivity of the alcoholic functions toward *tert*-butyldimethylsilyl or tri(isopropyl)silyl chloride was 5' >> 2' > 3'.¹²⁵ Again the 5'-silyl moiety was selectively cleaved in the presence of 2'- or 3'-silyl ethers. Based on this, 5'-silyluridine (70–75%) and the 2'-derivative (50–60%) were prepared from uridine.¹²⁵

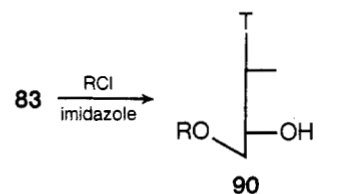

R	Yield, %
$-\text{Si}(\text{Me})_2-$	73
$(\text{C}_3\text{H}_7)_3\text{Si}-$	82
$\text{C}_5\text{H}_{11}\text{Si}-$	82

vi. Levulinyl Group. A recent communication discloses a simplified method for cleaving the levulinyl group by sodium borohydride reduction over the pH range of 5–8.5 through the intermediacy of **93**.¹²⁶ Levulinic esters were readily formed by

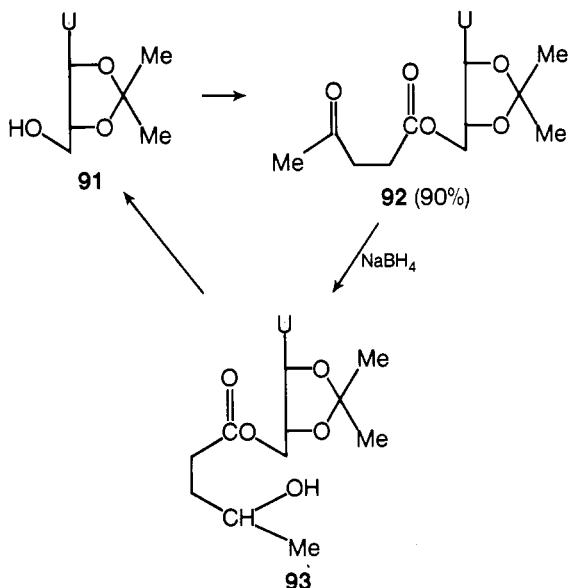

action of the anhydride upon the 5'- or 3'-hydroxyl functions of uridine and thymidine when other sites were masked. These ester derivatives were stable to acidic conditions.

d. Enzymatically Removable Groups

For Khorana's approach¹² to the synthesis of oligodeoxyribonucleotides (section V.C.1), the high selectivity and mild conditions of enzymatic reactions suggested the use of enzymatically removable masking groups for the 3' position.¹²⁷ Taunton-Rigby¹²⁸ investigated the hydrolysis of the dihydrocinnamoyl (**94**), D-(+)-dihydrocoumariloyl (**95**), and *o*-phenylenedioxyacetyl (**96**) esters of nucleosides and nucleotide chains by α -chymotrypsin. α -Chymotrypsin cleaved dcm and pda

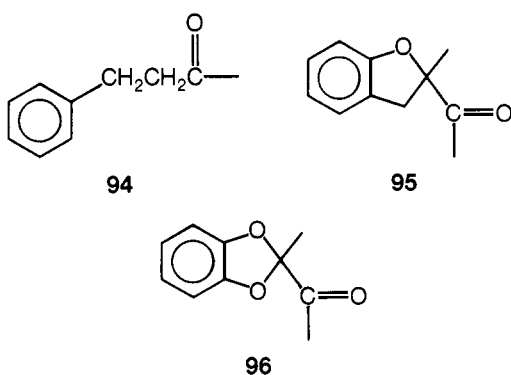

groups at 37 °C under neutral conditions much faster (less than 1 h) than dhc (8–16 h). However, *o*-phenylenedioxyacetyl and D-(+)-dihydrocoumariloyl chlorides were poor acylating agents, and their nucleotide esters were not stable enough for purification purposes. The suitability of the dihydrocinnamoyl moiety for protection was demonstrated by the stepwise synthesis of the tetranucleotide d-pTpCpApG (Scheme VIII). The yields at the di-, tri-, and tetramer stages were 54, 46, and 36%, respectively. It was also observed that the rate of enzymatic hydrolysis was faster for an oligonucleotide than for a mononucleotide.

e. Selective Blocking of the 3'-Hydroxyl End

The yield of condensation reaction creating an internucleotide linkage is generally less than 80%; hence the reaction mixture at the end of a coupling step always contains the starting nucleotide chain with an unreacted hydroxyl residue at its growing end. The separation of the elongated chain from the predecessor is difficult in most cases. Masking the free hydroxyl function of

SCHEME VIII

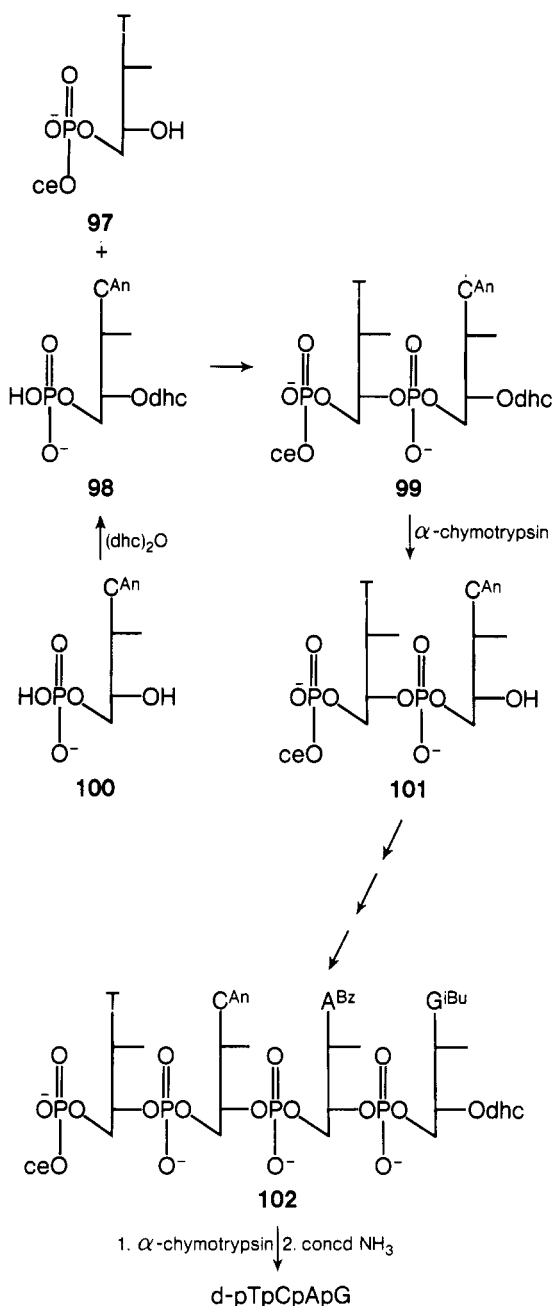

the unreacted oligonucleotide at least prevents it from entering into undesired condensations (Scheme XXVIII).

Agarwal and Khorana¹²⁹ observed that di- and higher deoxyribonucleotides with appropriate blocking agents on the 5'-terminal hydroxyl and all amino functions reacted quantitatively with aromatic isocyanates in pyridine at the 3'-hydroxyl end. Application of this reaction to oligonucleotide synthesis is outlined schematically for **109** (Scheme IX).

3. Simultaneous Protection of 2'- and 3'-Hydroxyl Functions

When an oligoribonucleotide is synthesized from the 3' end by adding mononucleotides or oligonucleotide blocks at its 5' end, or when the synthesis in the opposite direction is terminated, both 2'- and 3'-hydroxyl functions at the 3' terminus must be blocked. Selectivity for the *cis*-glycol system may be readily achieved by taking advantage of the stability of 5–5 fused ring systems. A variety of reagents which react with the *cis*-diol group to form five-membered dioxolane-type rings have been used.

SCHEME IX

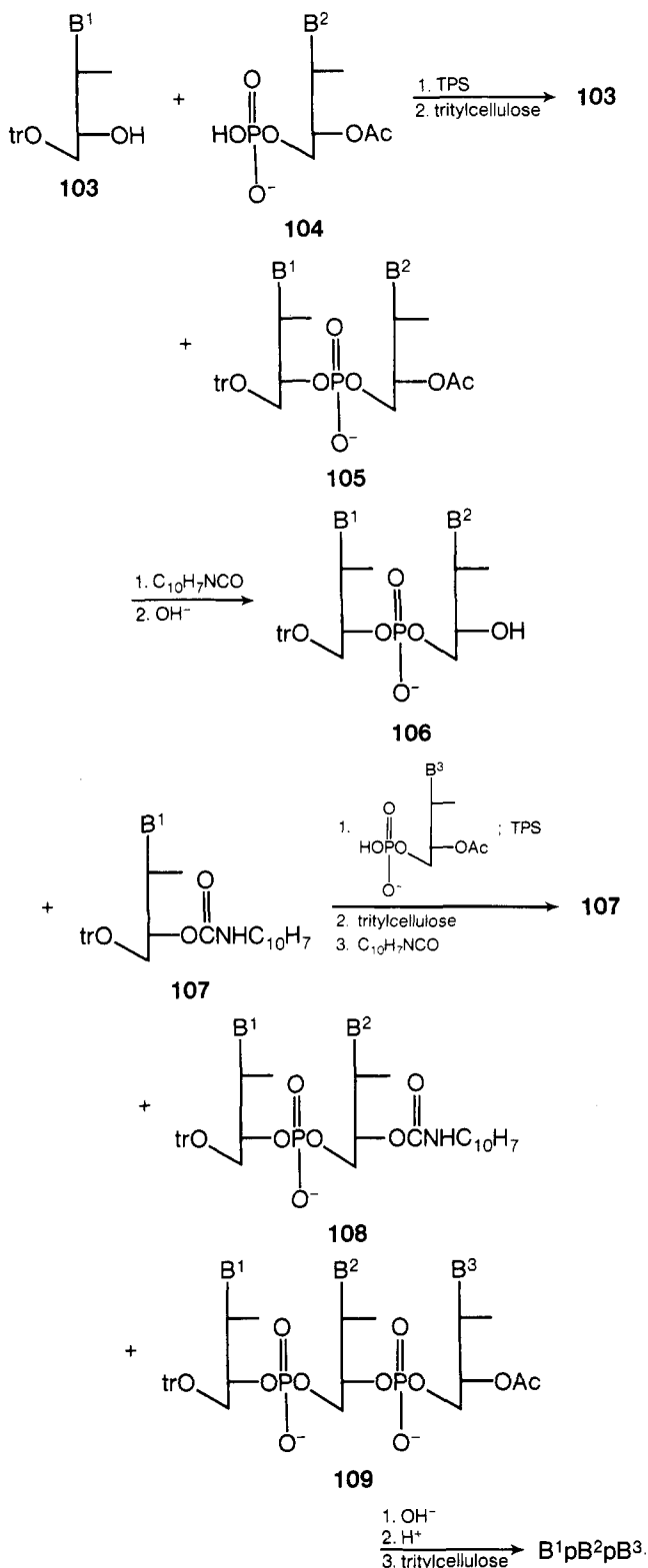

a. 2',3'-O-Alkylidene Derivatives

The acid-labile isopropylidene group, first employed four decades ago for protection of the 2',3'-*cis*-diol system,¹³⁰ is even today perhaps the most commonly employed group in ribonucleoside chemistry.^{131,132} The 2',3'-*O*-isopropylidene ketal **110** is isolated, usually in very good yield, by allowing acetone to react with a ribonucleoside in the presence of an anhydrous acid such as hydrogen chloride, *p*-toluenesulfonic acid, sulfuric acid, perchloric acid, or di-*p*-nitrophenyl phosphate¹³³ and a water scavenger such as ethyl orthoformate¹³⁴ or 2,2-dimethoxy-

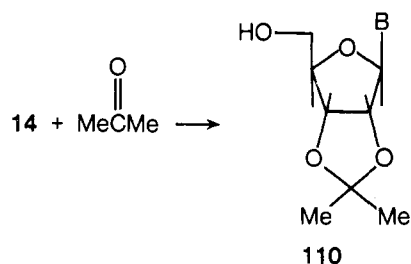

propane.¹³³ Similarly, reaction with a wide variety of ketones¹³⁵ and aldehydes^{45,136} yields alkylidene derivatives of varying acid susceptibility. For example, reaction with benzaldehyde leads to a mixture of diastereomeric benzylidene acetals **111** and **112**.¹³⁷ The isopropylidene and benzylidene blocking groups are cleaved by treatment with acid under conditions such that 3'-2' migration of the phosphate residue present in the system may take place.¹³⁸ Hence the more acid-labile *p*-dimethylamino- and 2,4-dimethoxybenzylidene acetals have been recommended.^{136,139}

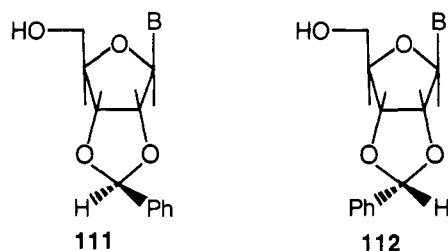

Despite the occasional purification difficulties associated with diastereomer formation, alkoxyalkylidene derivatives have been widely used because of their enhanced lability to acidic hydrolysis relative to isopropylidene ketals. They are readily formed by transesterification between ribonucleosides and appropriate orthoesters.¹⁴⁰ Reese³¹ and others have extensively employed the methoxymethylidene acetals since they may be hydrolyzed under mild conditions involving sodium citrate buffer (pH 5.6);²² the intermediate formates are readily removed under these conditions. On the other hand, when R in **113** is methyl or phenyl, treatment with aqueous acid gives rise to 2'/(3')-acyl esters, necessitating alkaline treatment for complete cleavage.

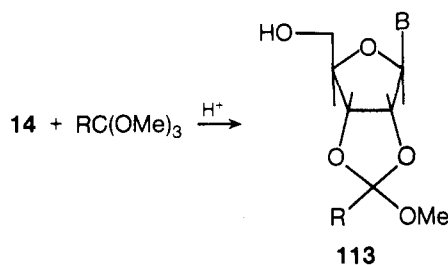

b. 2',3'-O-Cyclic Carbonates

As noted above, *p*-nitrophenyl- and 2,2,2-tribromoethyl chloroformates may be used to protect single alcohol function. In the presence of a *cis*-glycol group, however, the initially formed acyclic carbonate diester undergoes further intramolecular transesterification to yield the corresponding 2',3'-cyclic

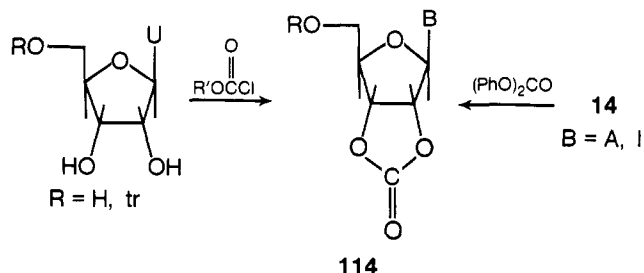

carbonate **114**.^{104,117} Cyclic carbonates^{141,142} have also been prepared with diphenyl carbonate¹⁴³ or by the hydrolysis of 2',3'-*O*-dimethoxymethylidene orthoesters **115**.¹⁴⁴ Compounds **114** are readily hydrolyzed under mild basic conditions (pH 8, 100 °C, and 15 min);¹⁴³ the use of cyclic carbonates in oligonucleotide synthesis has not been demonstrated.

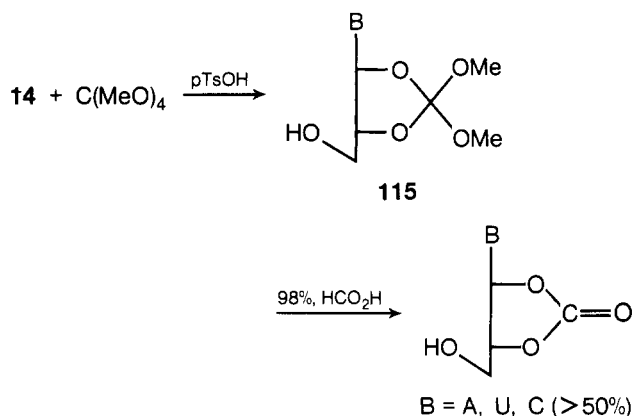

c. 2',3'-Cyclic Phosphates

The accessibility¹⁴⁵ and the highly specific opening of 2',3'-cyclic phosphates to 3'-nucleotides by various ribonucleases have made them valuable intermediates in the synthesis of di-¹⁴⁶⁻¹⁴⁹ and trinucleotides¹⁵⁰ (Scheme X). The removal of any protecting group present on the heterocyclic amino functions may be necessary before the cyclic phosphate is cleaved by RNAase M or T₁.¹⁵⁰

d. 2',3'-*O*-Phenyl Boronates

Although boric acid complexes of ribonucleosides are not sufficiently stable for use as protecting groups,¹⁵¹ 2',3'-*O*-phenyl boronate derivatives have been isolated^{152,153} and used for further reactions.¹⁵⁴ These boronate esters were hydrolyzed in water within 10 min and were cleaved by transesterification with ethylene glycol.¹⁵³

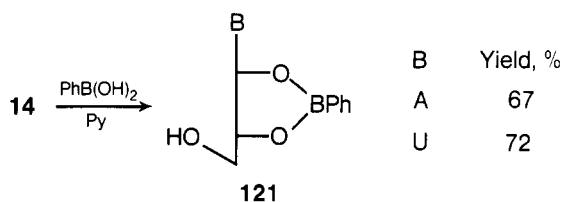

B. Phosphate Protecting Groups

1. Internucleotide Phosphate Protection

Difficulties in synthesis and purification of such relatively large molecules as oligonucleotides are often aggravated by the presence of negative charges associated with the internucleotide phosphate moieties (vide infra). A number of phosphate protecting groups designed to eliminate this difficulty by affording triester rather than diester condensation products have been developed. Such groups must, of necessity, be stable to the conditions of internucleotide bond formation as well as those required for the manipulation of various hydroxyl blocking groups.

a. 2,2,2-Trichloroethyl Group

The trichloroethyl group, originally introduced by Woodward¹⁵⁵ for the synthesis of cephalosporin, was first adapted to phosphate protection by Eckstein.¹⁵⁶ Various approaches to the requisite trichloroethyl nucleotides are illustrated in Scheme

SCHEME X

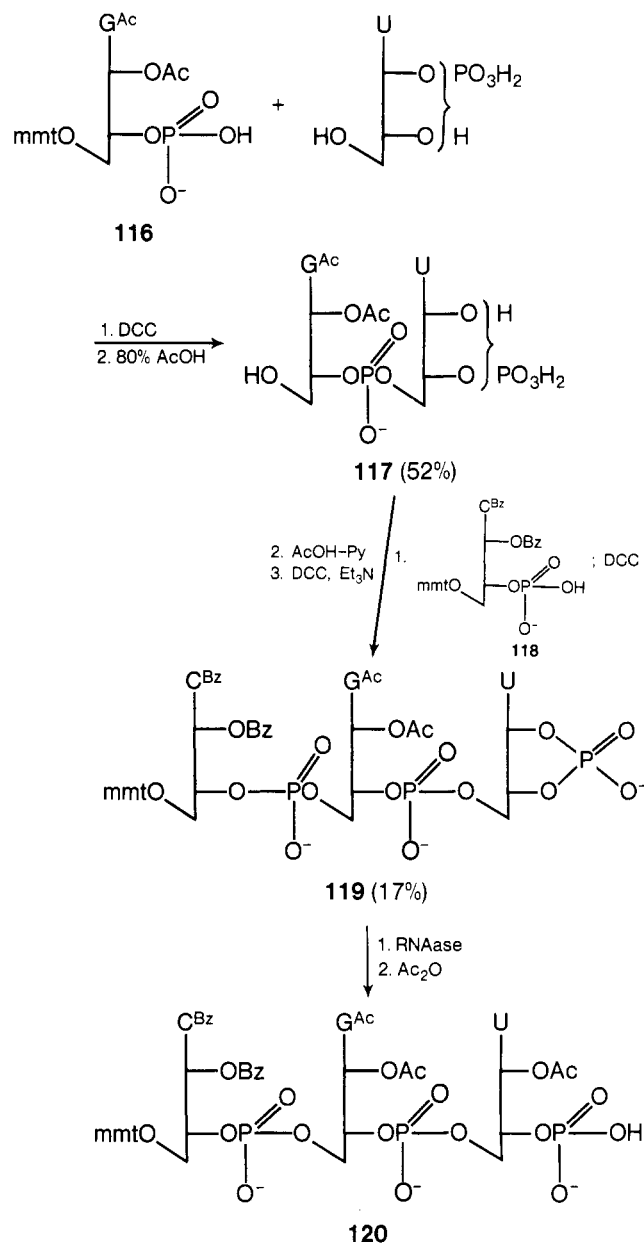

SCHEME XI

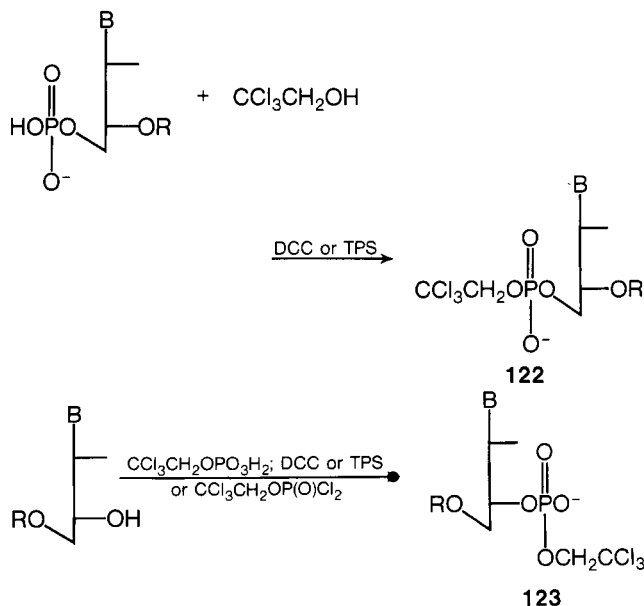

XI,^{85,157-159} yields generally exceed 50%. The protection is stable to acidic and slightly basic conditions; it is only slightly affected by 80% acetic acid and concentrated ammonium hydroxide.¹⁵⁸ The cleavage of the group had been effected by (i) zinc dust and 80% acetic acid,¹⁵⁷ (ii) copper-zinc couple in *N,N*-dimethylformamide,¹⁵⁸ (iii) sodium hydroxide in aqueous dioxane,⁸⁵ or (iv) zinc dust in pyridine containing acetic acid.¹⁵⁹

b. 2-Cyanoethyl Group

The 2-cyanoethyl group, initially used by Khorana for terminal phosphate protection,¹⁶⁰⁻¹⁶² was suggested by Letsinger¹⁶³ for masking internucleotide phosphate residues. The requisite reagents for introducing the protection are readily available, and the deblocking can be easily had under mild basic conditions involving ammonium hydroxide, conditions to which esters are, unfortunately, also susceptible.

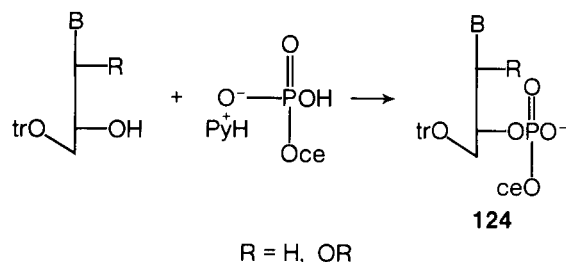

c. Phenyl and Substituted-Phenyl Moieties

These groups have been employed less frequently than the 2,2,2-trichloroethyl and 2-cyanoethyl groups although they are equally useful in protecting the internucleotide phosphate moiety. Phenyl, *o*-chlorophenyl, and *p*-methylthiophenyl 3'-phosphodiester of 5',2'-disubstituted nucleosides have been prepared and employed for oligonucleotide synthesis.^{31,164-166} Phenyl dichlorophosphate is an ambident phosphorylating agent which was used for the direct formation of the internucleotide bond between two appropriately protected deoxyribonucleosides.¹⁶⁵

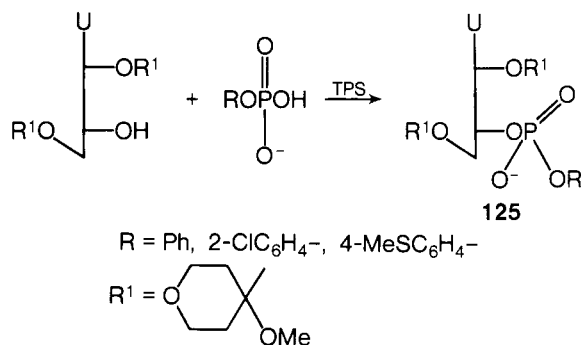

Attempts to apply the reaction to the far more hindered 2'-*O*-(4-methoxytetrahydropyran-4-yl)ribonucleoside failed in the absence of a catalyst.³¹ The use of 5-chloro-1-methylimidazole as catalyst led to phosphorylation of the hindered secondary 3'-hydroxyl in reasonable yields.¹⁴⁵ This catalysis is a potentially important phenomenon which deserves additional attention. Potassium hydroxide (0.1 M) in water-dimethylsulfoxide was suggested¹⁶⁷ to deprotect dinucleoside phosphate triesters without cleaving the phosphodiester bond to any significant extent.

d. Phenylthio Group

The possible use of the base labile phenylthio group in oligonucleotide synthesis via the phosphotriester method has been very recently reported¹⁶⁸⁻¹⁷⁰ (**126**).

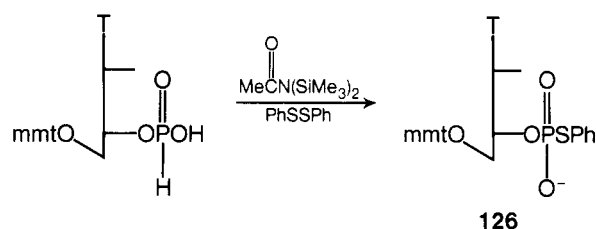

2. Protection of a Terminal Phosphate Group

Synthesis of an oligonucleotide chain bearing a 3'- or 5'-terminal phosphate may be accomplished by phosphorylation (chemical or enzymatic) of an appropriately protected preformed oligonucleotide. It is generally preferred, however, to initiate the synthesis with a nucleotide, the phosphate of which will be masked throughout oligomer preparation until its ultimate release as the 3'(5')-terminal phosphate. In addition to the usual stability requirements to all conditions required for oligonucleotide synthesis, these blocking groups must protect the phosphate against esterification or pyrophosphate formation; this is generally achieved through the selection of groups which sterically or electronically reduce phosphate reactivity. The 2-cyanoethyl⁵⁶ and 2,2,2-trichloroethyl^{158,171} groups described above were widely used for this purpose, but recent developments have led to phosphate protecting groups which, in addition to affording protection against unwanted side reactions, provide real advantages in product purification and ease of removal.

a. Substituted Phosphorothioates

The initial use of 5'-substituted phosphorothioates in nucleotide synthesis was by Cook and Nussbaum.¹⁷²⁻¹⁷⁴ The *S*-ethyl group was shown to have considerable stability to a variety of reaction conditions and, upon mild oxidation with iodine in aqueous dioxane, it was made susceptible to displacement by a number of nucleophiles (Scheme XII),¹⁷⁵ The full utility of the *S*-ethyl phosphorothioate moiety in masking phosphate function was convincingly demonstrated by Nussbaum, Cook, and their co-workers.¹⁷⁶⁻¹⁷⁸

b. Arylmercaptoethanol

The 2-arylmercaptoethyl protecting group, introduced by Narang,^{179,180} conferred hydrophobic character to its derivatives (**132**), thereby facilitating their separation from the more hydrophilic starting materials and condensing agents by chromatography on benzoylated DEAE-Sephadex. The novelty of the blocking group lies in the mode of its removal; periodate oxidation converted the sulfide to sulfoxide (**133a**). The greatly in-

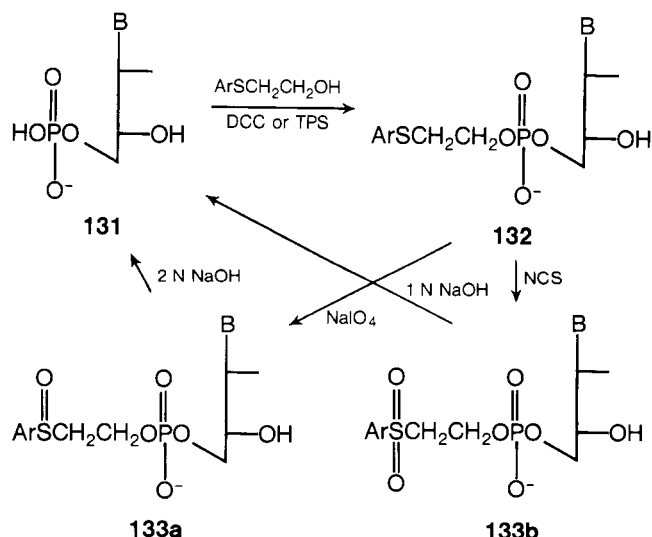

SCHEME XII

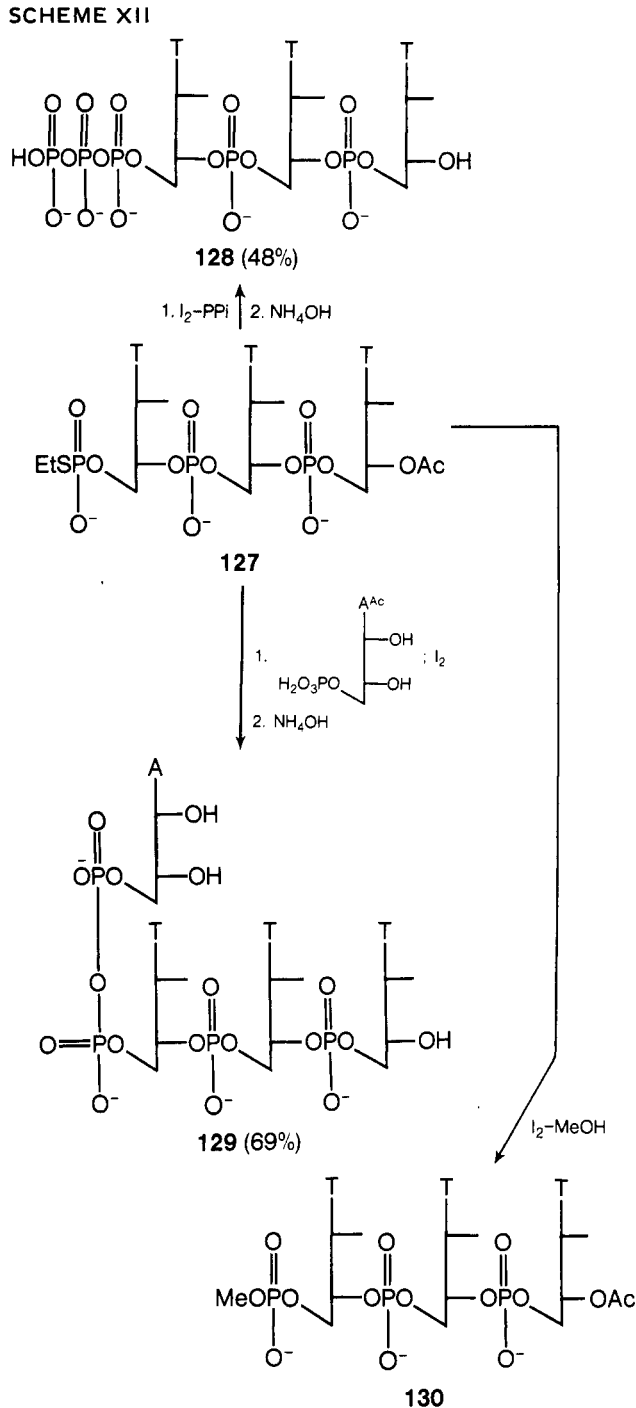

creased acidity of the α proton in the latter facilitated base-catalyzed β -elimination of phosphate. The 2 N sodium hydroxide used by Narang¹⁸⁰ led to removal of N-acyl protecting groups. The use of periodate oxidation prevented application of the reaction to oligoribonucleotides having a free 2',3'-terminus; this difficulty was later obviated by Khorana,¹⁸¹ who used *N*-chlorosuccinimide to oxidize **132** to the arylsulfonyl derivative **133b** prior to cleavage by 1 N sodium hydroxide. Obviously, this methodology is not applicable to incorporation of sulfur-containing nucleosides into oligomers.

c. Aryl and Aralkyl Phosphates

The advantage of having aryl groups in protected nucleotide chains is to make them extractable by organic solvents or readily separable by affinity chromatography. Particularly suited for this purpose is the *N*-trityl-*p*-aminophenyl group.¹⁸² Isolation of **136** or oligothymidylates bearing the protection by 7:3 chloroform-

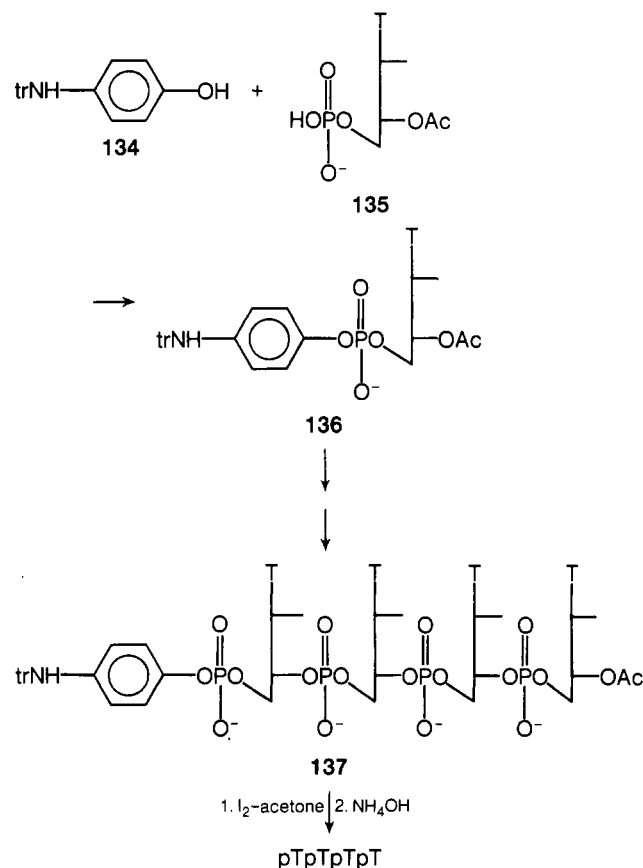

butanol extraction at each stage increased the overall yield (15%) and reduced the time of workup considerably. The group was more stable than aromatic phosphoramidates in anhydrous pyridine and was unaffected by isoamyl nitrite. The cleavage of *N*-trityl-*p*-aminophenyl residue from **137** was carried out in acetone containing iodine.

A number of other aryl and aralkyl protecting groups including benzhydryl,¹⁸³ α -pyridylethyl,¹⁸⁴ fluorene-9-methyl,¹⁸⁵ 2,4-dinitrophenyl,¹⁸⁶⁻¹⁸⁸ 4-chloro-2-nitrophenyl,¹⁸⁹ and various other aromatic derivatives¹⁹⁰ have been studied.

Two additional phosphate masking ethers, which have been recently described, need to be mentioned. These are the 1-oxido-2-pyridylmethyl¹⁹¹ and the *o*-nitrobenzyl¹⁹² moieties. The former is removed by treatment with acetic anhydride with concomitant acetylation of susceptible functions, requiring an additional treatment with methanolic ammonia for complete deblocking. The *o*-nitrobenzyl group, on the other hand, offers the clear advantage of photolability under conditions which do not affect the purine or pyrimidine bases. The application of these protective groups to oligonucleotide synthesis is yet to be demonstrated.

d. Phosphoramidates

Ikehara et al.¹⁹³ first evaluated the possible use of aromatic phosphoramidates^{148,194-197} for blocking the phosphate moiety.

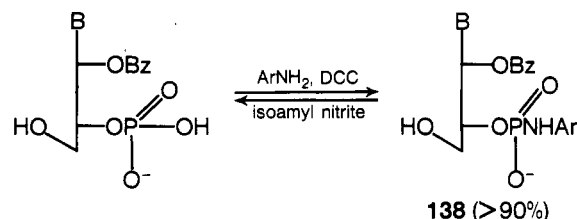

These workers used aniline and *p*-anisylamine and found that the amidate residue could be cleaved by isoamyl nitrate treatment in neutral buffered solutions. This approach was extended

by Khorana's group¹⁹⁸ who found that *N*-(*p*-tritylphenyl)phosphoramidates (**139**) could be converted to dinucleotides **141** which could be extracted from the reaction mixture into organic solvents. Pure dinucleotides **141** were readily obtained by precipitation. Alternatively, phosphoramidates of the types **139** and **141** could be separated from other components of the reaction mixture on columns of trityl cellulose or naphthylcarbamoyl-cellulose.⁸⁶

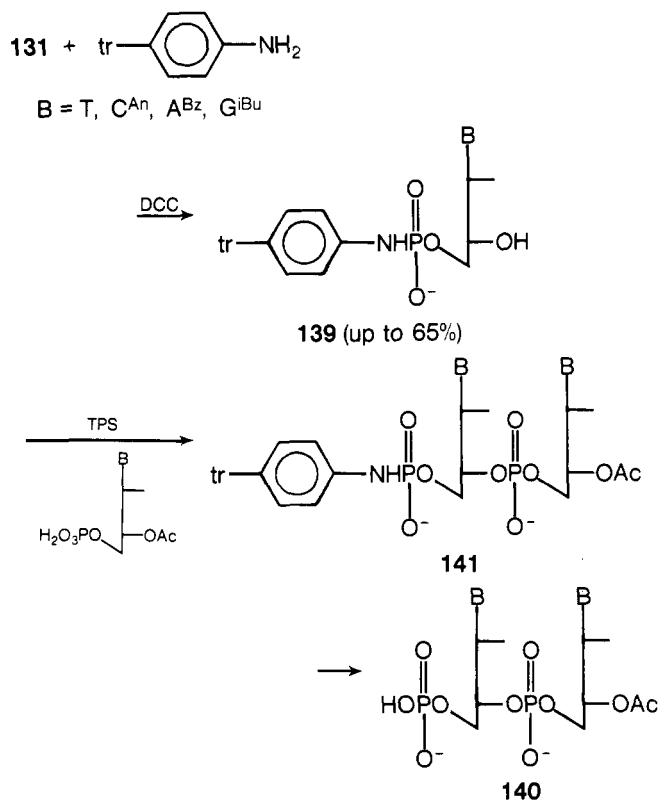

In contrast to the approaches described above, which rely upon increasing the hydrophobicity of an anionic molecule, Hata^{199,200} elected to attach a cationic "handle" to phosphate in order to enable separations using ordinary ion-exchange resins. His initial approach is outlined in Scheme XIII; it relies heavily upon the unexplained and astonishing ability of Dowex-50 (H⁺) resin to selectively and quantitatively adsorb mononucleotide **142** while not retaining dinucleotide **144**. In more recent work^{201,202} Hata has used the much more basic aniline derivative **146** for phosphoramidate formation and depended on tritylcellulose and DEAE-cellulose for separation and purification of a variety of deoxyoligonucleotides.

C. Protection of the Amino Functions on the Bases

Protection of the amino functions of adenine, guanine, and cytosine containing nucleosides and nucleotides often may be regarded as a necessary evil in oligonucleotide synthesis, evil because two additional steps are required (blocking and de-blocking) but frequently necessary in order to avoid undesired phosphoramidate formation with activated phosphate residues during condensation.^{203,204} An advantage is the general increase in solubility obtained as a result of masking the heterocyclic extranuclear amino groups.

Reese et al.²² first reported that satisfactory yields in the preparation of adenosyl(3'-5')uridine could be obtained without acylating the amino function. Recently Narang²⁰⁵ and Smrt²⁰⁶ reported the apparent superfluity of amino protecting groups on adenosine and guanosine. The yields and the purity of dinucleotides were essentially unaffected by the presence or ab-

SCHEME XIII

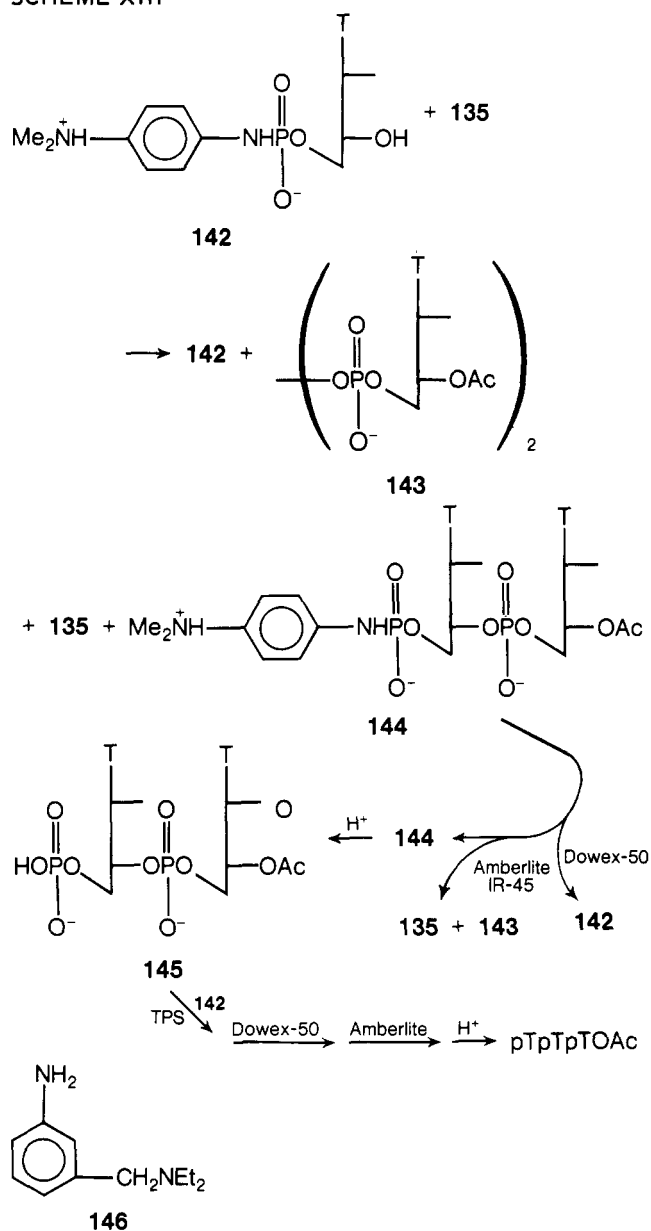

sence of blocking agents on the amino functions. On the other hand, the use of cytidine with a free amino group led to an *N*-phosphorylated compound as the major (ca. 42%) product.²⁰⁵ Earlier Khorana²⁰⁷ also observed the major reaction between 3'-*O*-acetylthymidine 5'-phosphate and 5'-*O*-trityldeoxycytidine in the presence of DCC to be phosphorylation of the amino moiety.

Relatively few types of amino protecting groups have been developed, primarily because the criteria they must meet are much less stringent than those for hydroxyl blocking groups. Generally the bases are *N*-substituted prior to initiation of internucleotide link formation and remain blocked until the chain is completely assembled. Thus, the protective groups need only be stable to all the chemical manipulations leading to the synthesis of an oligonucleotide, and be removable under conditions which do not permit cleavage of the chain.

1. *N*-Dimethylaminomethylene Group

This group was introduced and developed by the Czech group for the selective masking of heterocyclic amino functions in nucleosides²⁰⁸⁻²¹⁰ and nucleotides.²¹¹⁻²¹² Treatment of adenosine, cytidine, guanosine, and their 2'-deoxy analogs with dimethylformamide dimethyl acetal in dimethylformamide afforded

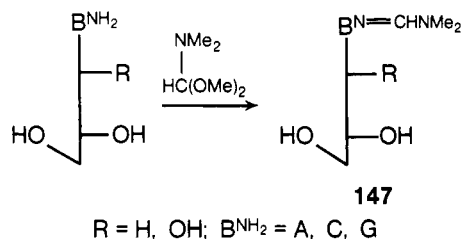

almost quantitative yields of the corresponding *N*-dimethylaminomethylene derivatives (**147**).

Cleavage can be brought about in acidic as well as basic solutions; shaking with ammonia is often used. As pointed out in Scheme I the reagent can also be used to selectively protect amino groups on di- and presumably higher oligonucleotides. A note of caution should be added, however; in the presence of a uridine residue, the corresponding dineopentyl acetal is preferred to avoid methylation of the uracil ring. The major disadvantage to the *N*-dimethylaminomethylene moiety is its susceptibility to both acid and base; reintroduction is often required prior to subsequent steps.

2. Acyl Groups

Ease of amide formation with heterocyclic amino functions has led to widespread use of various acyl groups for amino protection. One major limitation of using *N*-acyl derivatives is that glycosidic bond is made more susceptible to hydrolytic cleavage. This observation is of greatest significance with the 2'-deoxynucleosides, which are quite acid labile even in the absence of *N*-acyl groups.

Although *N*-acetyl derivatives of nucleosides and nucleotides were utilized by early workers,^{210,213,214} the limited solubility of these derivatives in pyridine and the instability of *N*-acetyl protection to an acidic medium²⁰⁷ restricted their use.⁵² Depending upon the base lability of *N*-acylated bases, different acyl groups have emerged for different bases. At the present time, anisoyl for cytosine,²⁰⁷ benzoyl for adenine,²¹⁵ and isobutyryl²¹⁶ or 2-methylbutyryl for guanine seem to be the acyl moieties of choice.^{12,198} They are generally removed by treatment with concentrated ammonium hydroxide or with 1:1 mixture of methanol and butylamine.²¹⁷ Scheme XIV illustrates two common ways of preparing nucleosides **149** and **151** with protected amino groups. The lability of the ester function compared to amide is extensively exploited in reactions of this type. Selective acylation of the basic amino function²¹⁸ is seldom carried out because some ester formation almost inevitably occurs.

SCHEME XIV

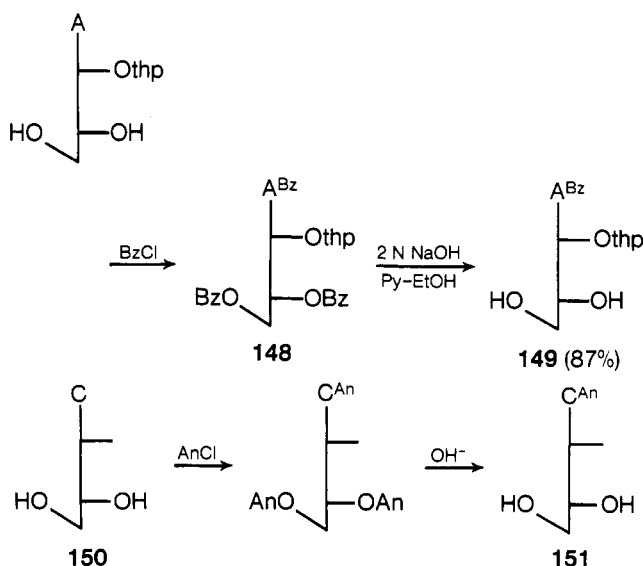

3. Isobutyloxycarbonyl Group

Whenever hydrazine has to be used in any of the synthetic steps, acyl groups on amino functions may be cleaved. To overcome this limitation isobutyryl chloroformate has been introduced¹¹⁵ to protect the amino groups on cytosine and adenine since the resulting carbamate derivative is more stable toward hydrazine than the amide moiety. This principle is brought out by considering dinucleotide formation from **154**; hydrazine removal of the benzoylpropionyl group may be carried out without affecting the isobutyloxycarbonyl function at the N⁴ site of the cytosine ring. The latter in turn may be hydrolyzed with concentrated ammonium hydroxide.

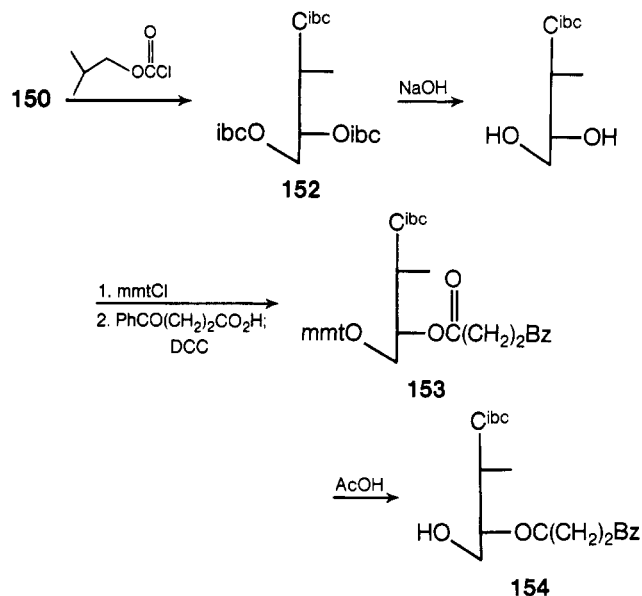

IV. Internucleotide Bond Formation

The key reaction in any oligonucleotide synthesis is joining two components, one containing a free phosphate function and another a hydroxyl, to form a 3-5 internucleotide bond. A reduced yield due to uncontrolled side reactions at this stage may waste valuable starting materials and lead to undesirable consequences in the yield and the purification of the product. A few synthetic reactions have been devised which approach the ideal of keeping the yields high within reasonable periods of reaction time.

A. In Situ Activation of the Phosphate Function

The fragments to be linked having unprotected phosphate and hydroxyl residues are brought together in this method without prior activation. The condensing agents commonly employed are dicyclohexylcarbodiimide (DCC), mesitylenesulfonyl chloride (MS),²¹⁹ and 2,4,6-triisopropylbenzenesulfonyl chloride (TPS).²²⁰ Other conventional condensing reagents such as ethoxyacetylene,²²¹ *N*-ethyl-5-phenylisoxazolium fluoroborate,^{219,221,222} trifluoroacetonitrile,²²³ picryl chloride,²²⁴ mesityl chloride,²²⁵ and carbonyl bis(imidazole)²¹⁹ proved to be of no practical value for oligonucleotide synthesis. Steric constraints caused by the presence of substituents in the ortho positions of MS and TPS reduce the amount of sulfonation of the free hydroxyl group present in one of the components. The intermediate DCC, MS, or TPS activated nucleotide is usually allowed to react in situ with the appropriate alcohol function of the other fragment. The generality and the simplicity of this method are responsible for its wide popularity. Of the three common condensing agents DCC is least reactive; it does not effect coupling when the phosphate residue bears an additional substituent as in phosphotriester method (vide infra). TPS is often the reagent of choice. However, MS, which is more soluble in pyridine and more reactive than

TPS, is preferred for block synthesis. The mode of action of these condensing agents has not been fully elucidated.^{159,226-228} The coupling step is usually carried out in anhydrous pyridine, which by far seems to be the best solvent; the reaction is very sensitive to moisture and a special apparatus for it has been described.²²⁹

There are three drawbacks to MS and TPS, which restrict their use. The liberation of free hydrogen chloride during the activation step sometimes caused unwanted reactions. Sulfonation was not completely eliminated even with the most sterically hindered TPS. Finally, removal of arylsulfonic acid after the reaction was difficult, particularly for the triester method. To overcome these shortcomings while retaining the coupling power of MS and TPS, a few modifications have been attempted.

p-Toluenesulfonyl and mesitylenesulfonyl imidazolides (**155a** and **155b**) and the less reactive 2,4,6-triisopropylbenzenesulfonyl imidazolide (**155c**) were found²³⁰ to be slower than TPS in bringing about the formation of the phosphodiester linkage.

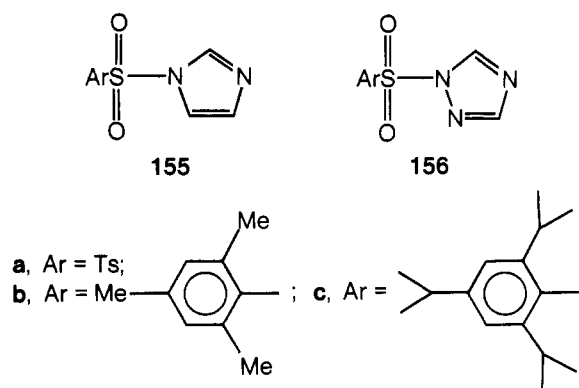

Nevertheless, sulfonation of hydroxyl function was not detected even with excess **155**, and acid-sensitive bonds in the starting materials were unaffected. Narang et al.²³¹ recently reported that arylsulfonyl 1,2,4-triazolides (**156**) were more reactive than the imidazolides. Both **155** and **156** may be easily obtained from arylsulfonyl chlorides and the appropriate heterocycle in the presence of triethylamine. The sulfonamides are gaining popularity.^{169,232}

Attachment of the reagent to a polymer support was investigated by Rubinstein and Patchornik.²³³ The reactivity of poly-(3,5-diethylstyrene)sulfonyl chloride (**157**) was comparable to that of TPS in coupling ability. The sulfonic acid product was removed simply by filtration of the polymer at the end of the reaction. The extent of sulfonation was slightly higher than that encountered with TPS, but the resulting sulfonates were removed with the polymer.

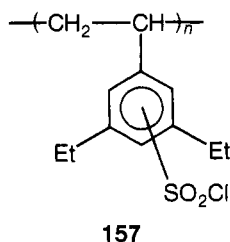

A recently introduced condensing agent²³⁴ is the addition compound of 2,2'-dipyridyl disulfide and triphenylphosphine. This effective reagent, which has been employed successfully for the synthesis of peptides²³⁴ and for obtaining mixed esters of phosphoric acid and pyrophosphate,^{235,236} was found to be useful in nucleotide chemistry as well.^{201,202}

All of the coupling reagents described above have in common a rigorous requirement for anhydrous conditions. It seems somewhat paradoxical, then, to consider phosphodiester bond formation in aqueous solutions. Nonetheless, coupling reactions

in aqueous solution brought about by water-soluble condensing agents such as **158**²³⁷ and **159**²³⁸ have been demonstrated. The

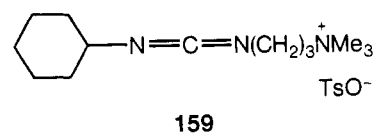
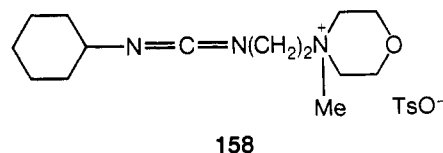

technique requires a complementary template in order to position the hydroxyl of one nucleotide in proximity to the activated phosphate of the next for effective competition with water molecules. Naylor and Gilham²³⁹ observed 5% dimerization of thymidine hexanucleotide in the presence of both the reagent **159** and polyadenylic acid at -3°C in 1 M sodium chloride solution. Despite the understandable low yield, the method may be valuable for repairing an isolated phosphodiester bond break in natural polymers and for adding single nucleotides to a long oligonucleotide on a suitable template. Low temperature and viscous solutions may be expected to increase the yield of such reactions. The use of 1-ethyl-3-(3-dimethylaminopropyl)carbodiimide²⁴⁰ hydrochloride for chemical polymerization will be discussed in section V.B.

B. Coupling through Elimination of HX (X^{-} , a Good Leaving Group)

The presence of a good leaving group X^{-} on phosphate or at the 5'(3') position amounts to prior activation; nucleophilic displacement of HX may lead to an internucleotide linkage. Since these preactivated reactions are usually more involved than in situ activation, they have been reported only sporadically (**161**²⁴¹ and **162**¹⁶⁴). Specificity is often increased because only one

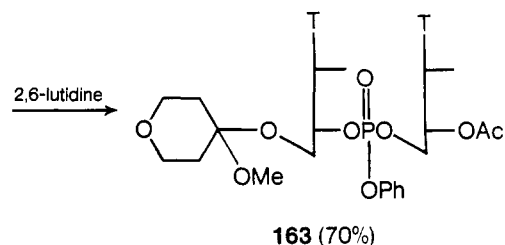
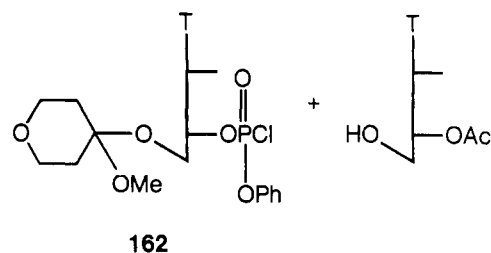
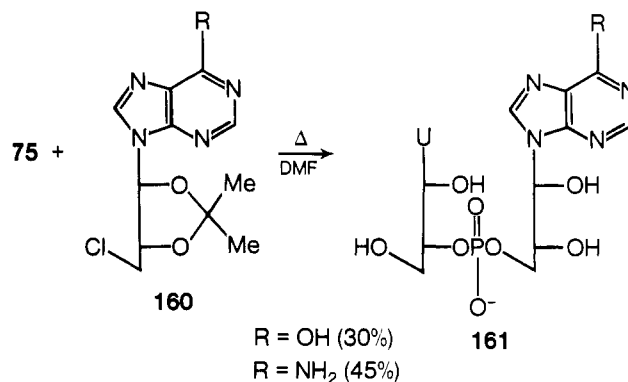

reactive site is present in each molecule. Protective groups for amino functions on the bases are sometimes not necessary, and the formation of pyrophosphates, a serious problem with TPS, is also precluded in most cases.

Reaction between an activated phosphate and a nucleoside alkoxide anion generated by an anhydrous strong base (e.g., potassium *tert*-butoxide) has been evaluated.²⁴² The formation

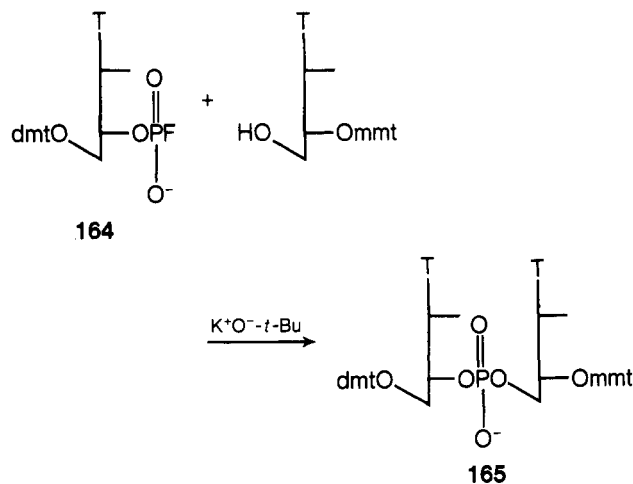

of **166** was complete in 10 min, and the yield was more than 80%. The method suffers from three limitations: (i) the lability of the glycosidic bond to strong anhydrous base, (ii) the low solubility of the potassium salts of oligodeoxyribonucleosides in DMF, and (iii) the relative lack of availability of the requisite phosphorofluoridates.

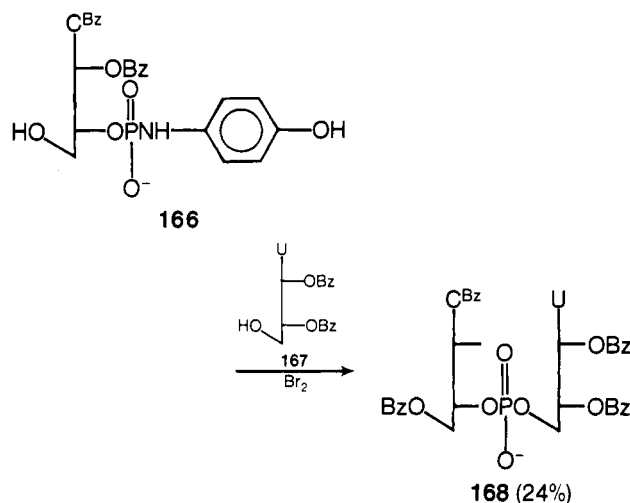

Activation of phosphate through conversion to a phosphoranilidate moiety has been reported by Ikehara.²⁴³ Since phosphoranilidates can be employed for phosphate protection (vide supra), use of these compounds directly in chain elongation step is an advantage, particularly in block synthesis. Further investigation is needed to test the generality of this reaction.

The mercury(II) chloride oxidation of a nucleoside 3'-phosphite attached to a polymer support in presence of a nucleoside was investigated by Kabachnik et al.²⁴⁴ to generate a phosphodiester linkage. The yields were good only for dinucleotides, but protecting groups for hydroxyl and amino functions were not needed and phosphorylation at amino nitrogen was not observed.

Letsinger²⁴⁵ has recently published a synthetic sequence (Scheme XV) for the formation of internucleotide linkages which is fast and compatible with most common blocking agents. The procedure uses the highly reactive aryl phosphodichloridites for formation of a triester of phosphorus acid; conversion to the requisite phosphate triester is readily carried out by oxidation with iodine.

SCHEME XV

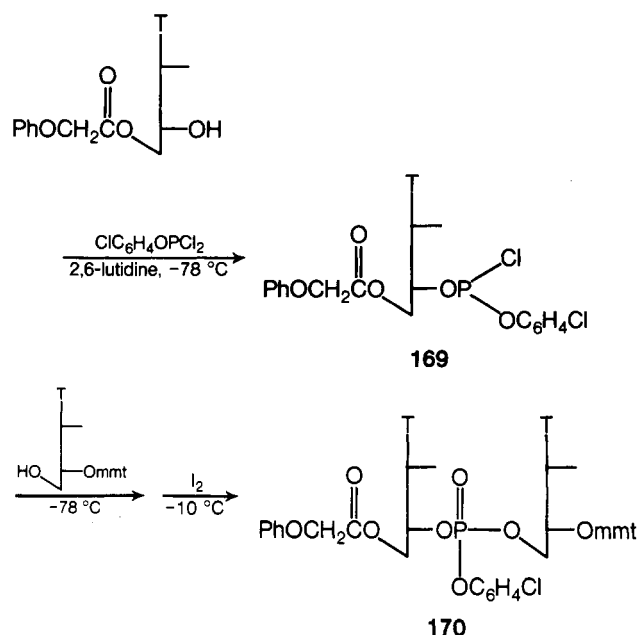

C. Through Cyclonucleosides

Cyclonucleosides (also called anhydronucleosides) such as **171**, which have a very good intramolecular leaving group, are susceptible to nucleophilic attack by the phosphate moiety of another nucleotide to produce a dinucleotide. For example, treatment of **171**, which was rendered more susceptible to nucleophilic attack by *N*-acetylation, with an equivalent amount of uridine 2'(3')-phosphate yielded **172**.²⁴⁶

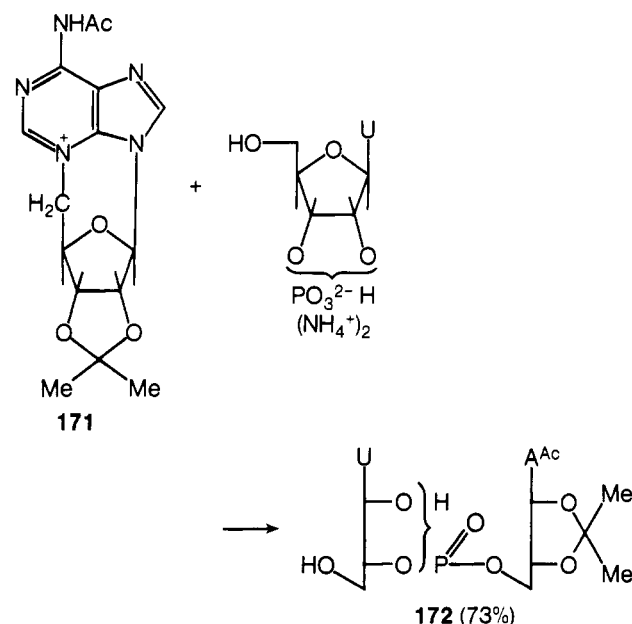

It is apparent that this reaction shares with reactions described above the advantage of specificity with regard to the site of nucleophilic attack. For this reason there was considerable enthusiasm for using pyrimidine²⁴⁷⁻²⁵³ and purine^{246,254-256} cyclonucleosides as intermediates in dinucleotide synthesis during the late sixties. Representative examples are provided in Scheme XVI. Since a 3'-ribonucleotide with an unprotected 2'-hydroxyl function upon reaction with a 2,5'-cyclonucleoside may lead to a mixture of 3'-5' and 2'-5' dinucleotide monophosphates,²⁴⁸ reaction between a 2,3'-cyclonucleoside and a 5'-ribonucleotide^{250,252} is an advantageous modification. The utility of cyclonucleosides in oligonucleotide synthesis seems

SCHEME XVI

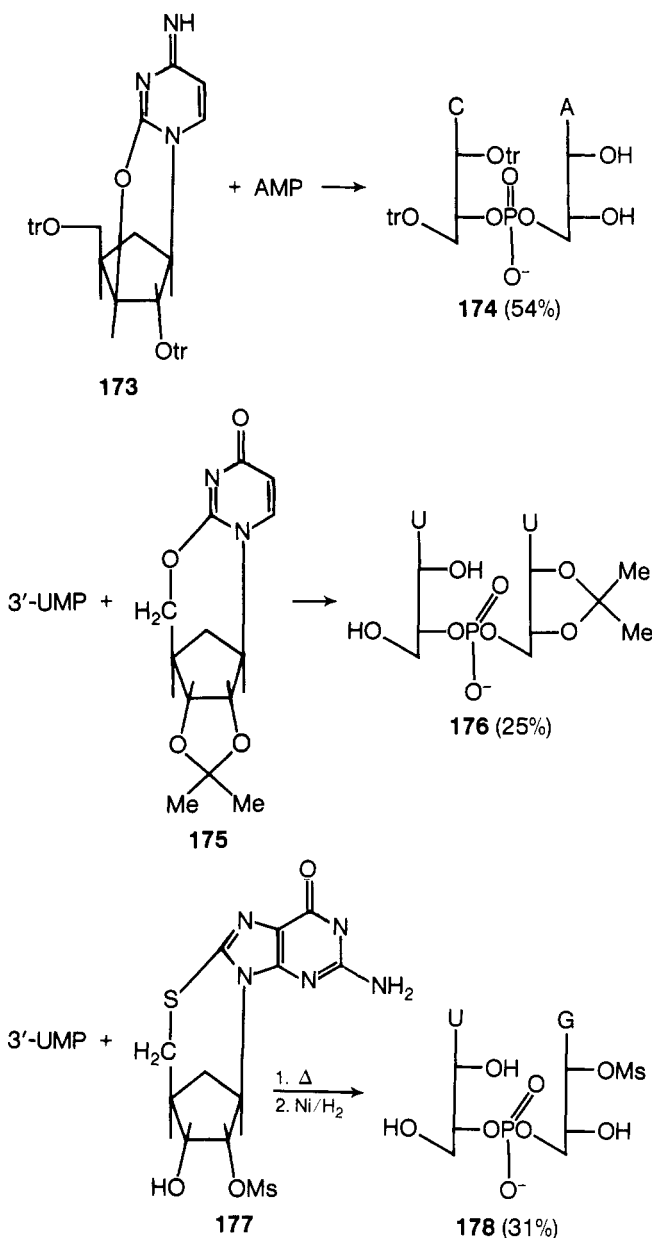

to depend on large-scale preparation of di- or trinucleotides ready for block synthesis. However, investigation in this direction has diminished, primarily because of the lack of convenient synthetic procedures for the preparation of cyclonucleosides.

V. Synthesis

A. Nonspecific Phosphodiester Linkage

During the formation of a diribonucleotide, if the 2'-hydroxyl function is not masked in the nucleoside destined to be at the 5' end, both 3'-5' and 2'-5' isomers are invariably formed. This section is a short account of reactions which led to such mixtures.

Michelson's early method^{214,257} for the preparation of a diribonucleotide consisted of the condensation of a ribonucleoside 2',3'-cyclic phosphate (**179**) with a 2',3'-isopropylidene acetal of a nucleoside in the presence of diphenyl chlorophosphate and tributylamine leading to a mixture of 3'-5' and 2'-5' dinucleoside monophosphates. The major drawback of this approach is that at the end of condensation the isomers must be separated prior to addition of another nucleotide. Recent

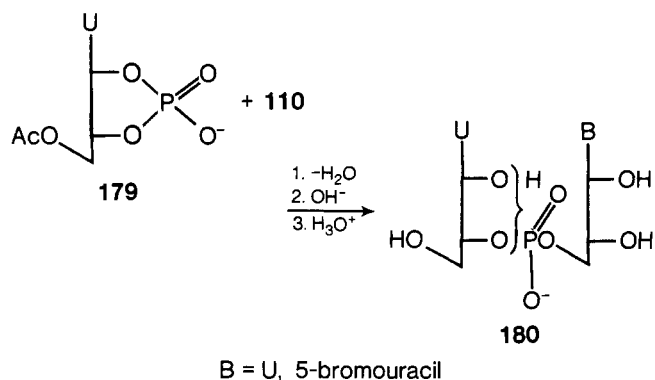

advances in ion-exchange chromatography,²⁵⁸ gel filtration,²⁵⁹ ionophoresis on cellulose,²⁵⁷ or DEAE-cellulose paper²⁶⁰ and ion-exchange thin-layer chromatography²⁶⁰ techniques have enabled facile separation of the isomers. For example, the mixture of 2'-5' and 3'-5' isomers of **180** (B = 5-bromouracil)

SCHEME XVII

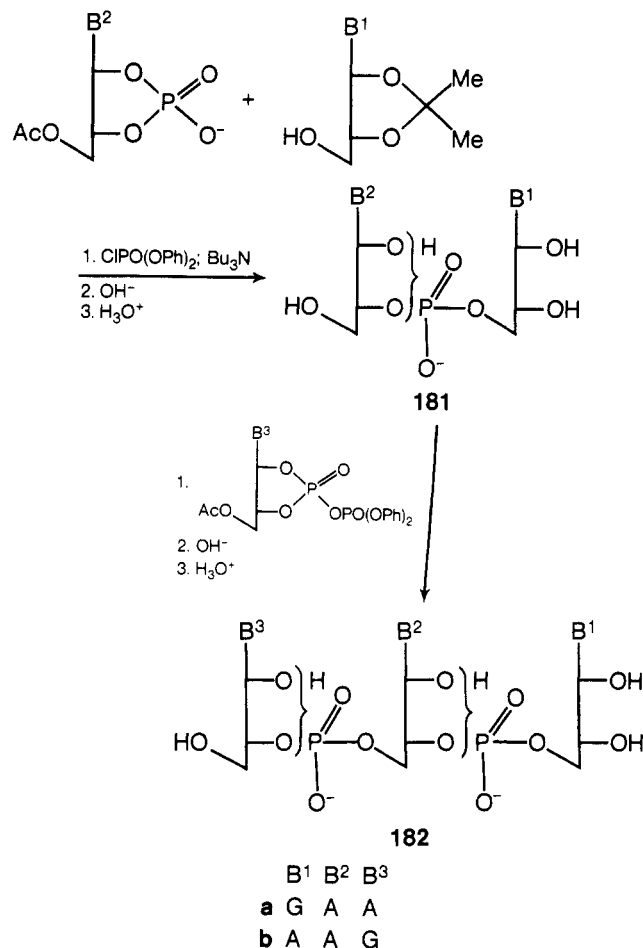

was separated on a column of Dowex-1 X 2 (formate) with sodium formate (pH 5) as the eluent. This ability to separate the isomers renders approaches such as those in Scheme XVII feasible under two sets of circumstances. First, if both 2'-5' and 3'-5' linked oligonucleotides are desired, it is unnecessary to carry out several blocking and deblocking steps.^{261,262} Second, large-scale preparation of dinucleotides can be made simpler by minimizing the number of protecting groups and carrying out the separation just once at the completion of the coupling step. Miura and Ueda²⁶³ found this shorter method particularly useful for producing diribonucleoside monophosphates having adenine or guanine at the 3'(2') end; the yields of the unprotected mixtures were more than 70%.

B. Chemical Polymerization

This term as used here refers to uncontrolled condensations leading to oligonucleotides with repeating units. The repeating unit may be either a single nucleotide or a small chain of nucleotides. In the case of ribonucleotides the 2'-hydroxyl is most often protected in order to yield C_{3'}-C_{5'} internucleotide linkage exclusively. The product of polymerization is a mixture of oligonucleotides of varying lengths in addition to products of any side reactions.

1. Polymerization with Condensing Agents

One of the first studies on oligomerization of ribonucleotides²⁶⁴ involved treatment of a 1:4 mixture of pyridinium 2',5'-di-*O*-acetyluridine 3'-phosphate and 2'-*O*-acetyluridine 3'-phosphate with DCC. Since short oligonucleotides bearing a 3'-phosphate residue have a marked tendency to form 3',5'-cyclic derivatives (**184**), the incorporation of 5'-masked monomer was expected to minimize that side reaction. At the end of polymerization, the reaction mixture was treated with acetic anhydride to remove the P¹,P²-di(nucleotidyl)pyrophosphates and with ammonia to remove the acetyl groups; homologous oligouridylic acids (**183**) up to the hexanucleotide were isolated and identified while higher oligomers and **184** were also detected. The yields of both **183** and **184** decreased with increase in chain length, as expected on the basis of probability.

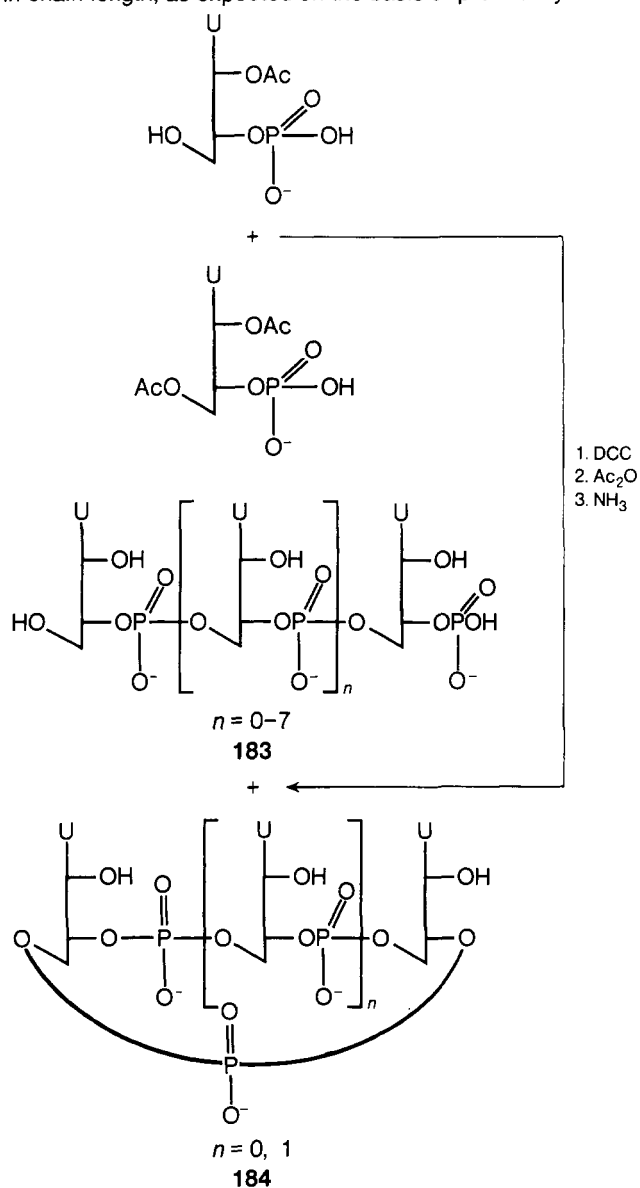

Similarly, Khorana's group prepared thymidine,²⁶⁵ deoxyguanosine,²⁶⁶ deoxycytidine,²⁰⁷ deoxyadenosine,²¹⁵ and adenosine²⁶⁷ oligonucleotides and separated them by chromatography on a column of DEAE-cellulose. Copolymerization of *N*,3'-*O*-diacetyldeoxycytidine 5'-phosphate (25%) and thymidine 5'-phosphate (75%) resulted in a homologous series of oligothymidylates (**185**) with deoxycytidine at the 3' end.²⁶⁵

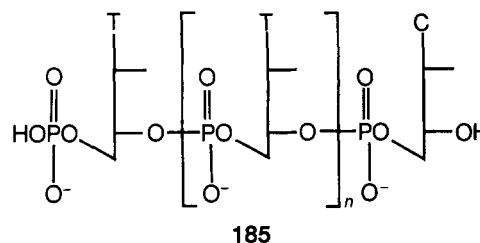

With slight modifications the above procedure has been applied by others²⁶⁸⁻²⁷⁰ to the preparation of oligomers of other nucleotides. In order to obtain oligonucleotides possessing the naturally occurring 5'-phosphate and 3'-hydroxyl termini, Straus and Fresco²⁷⁰ started with pyridinium salts of monomer *N*-benzoyl-2'-*O*-tetrahydropyranylguanosine 5'-phosphate and 3'-terminator *N*-benzoyl-2',3'-di-*O*-tetrahydropyranylguanosine 5'-phosphate. DCC activated polymerization of monomer and terminator in the ratio of 4:1 yielded mainly tetraguanylate along with lesser amounts of higher oligomers.

Short chains of oligothymidylates up to the hexamer were also prepared on a Merrifield resin support²⁷¹ as well as on a soluble polymer support.²⁷² Self-condensation of a modified nucleotide has also been reported.²⁷³

2. Use of Cyclonucleoside Phosphates

The potential of *O*², 5'-cyclothymidine 3'-phosphate (**186**) for the formation of oligomers through repeated self-condensations was recently explored by Nagyvary and Nagpal.²⁷⁴ Since **186** contained both the nucleophile and the leaving group, an external source of activation for coupling was unnecessary and pyrophosphate formation was not observed. Oligonucleotide chains (**187**) 2-12 units long were obtained and were analyzed on a Sephadex G-25 column. The practical use of this interesting approach depends on the accessibility of the requisite starting materials.

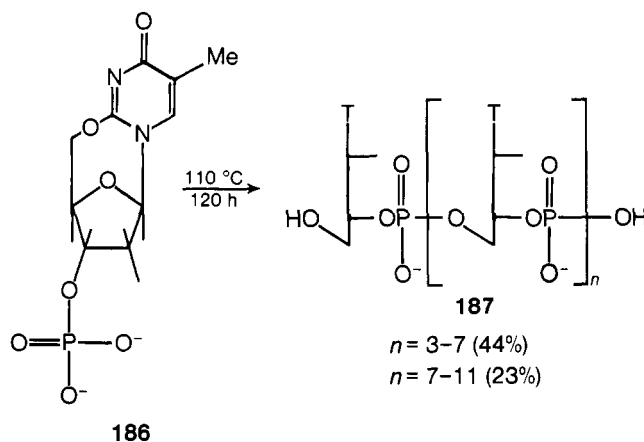

3. Catalyzed Polymerizations

Thermal polymerization of unprotected 2'-deoxyribonucleoside 5'-phosphates catalyzed by protic acids has been reported by Pongs and Ts'o.^{275,276} Pyrimidine nucleosides in refluxing DMF were polymerized to a mixture of oligomers with structural formulas of (pN)_n and (pN)_np. β-Imidazolyl-4(5)-pro-

TABLE I. Yield of Block Polymerization Using Condensing Agents

Monomer without protective groups	Approximate yields after deblocking, %					
	Cyclo-monomer	Monomer	Cyclo-dimer	Dimer	Trimer	Tetramer and higher
d-pTpG	21.4		4.5	24.5	9.7	7.8
d-pTpC	31.7		3.4	16.4	10.0	19.5
d-pCpGpA	16.00	27.5		21.0	8.0	11.6
d-pCpGpT	12.7	28.0		14.0	8.4	6.3
d-pApApG	10	29		30	8	4
d-pApApApG	14	54		11	1	
d-pApTpCpG	12.5	29.5		11.5	6.5	

panoic acid and triethylammonium chloride were observed to be the best catalysts, yielding up to 60% polymerization. Since the glycosyl bond in purine nucleotides is less stable to acidic conditions, similar preparation of oligopurinylic acids was less successful. Although 3'-5' cyclic nucleotides and pyrophosphates were not detected in the final product, 5-10% of the oligomers were composed of at least one 5'-5' phosphodiester bond. Pyrophosphate **188** was found to be an early product and was thought to play an important role in self-condensation.

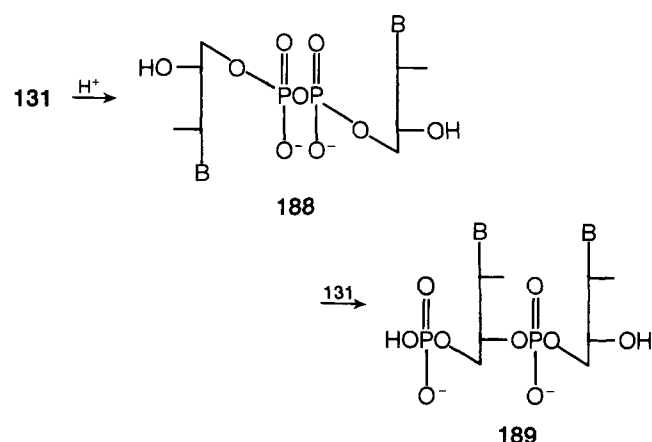

"Polyphosphoric ester" condensation of 3'- or 5'-nucleotides yielded high-molecular weight compounds²⁷⁷ which did not undergo complete degradation by ribonuclease;²⁷⁸ they were probably cross-linked and partially substituted. Hayes and Hansbury²⁷⁹ reported that ethyl polyphosphate and 5'-thymidylic acid did not give long polymers with 3'-5' linkages.

Zinc ion catalyzed oligomerization of adenosine or uridine 5'-phosphorimidazole has been studied recently.²⁸⁰ The maximum yield of oligoadenylic acids (up to tetramer) was only 25.2% and 76-90% of the internucleotide linkages were 2'-5' rather than 3'-5'.

Another example of a similar process is provided by oligomerization of thymidine 5'-triphosphate in presence of thymidine 5'-diphosphate, cyanamide, and 4-amino-5-imidazole-carboxamide under drying conditions at 60-90 °C.²⁸¹ These thermal polymerizations illustrate possible pathways for prebiotic polynucleotide synthesis.

4. Block Condensation

Oligomerization of a small chain of nucleotides with unprotected 5'- or 3'-hydroxyl and 3'- or 5'-phosphate ends enables one to obtain larger oligomers containing more than one kind of nucleotide. Separation of the product mixtures is greatly facilitated by the greater disparity in molecular weight between successive members than is the case in mononucleotide oligomerization. However, the yields of polymerization for the self-condensation of appropriate oligonucleotides (Table I) are still low,^{162,282-285} although the tendency to form 3',5'-cyclic

derivatives decreases with the length of monomer used. One example of block polymerization is provided by the TPS activated self-condensation of **190**.²⁸⁷

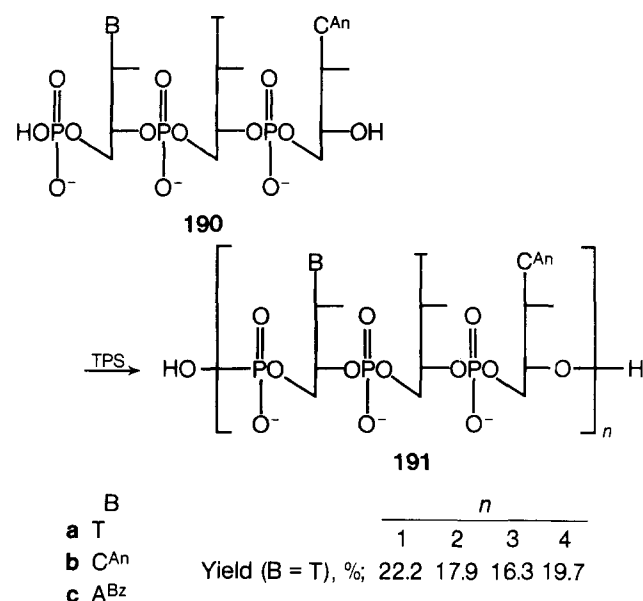

5. Polymerization on Templates

In chemical polymerizations, as seen above, the yield of coupled product decreases abruptly for oligomers of longer chain length.²⁸⁴ Hence the effect of complementary templates on the yield of repeated self-condensation has been studied.

Miles and co-workers were first to observe that under conditions favoring the formation of triple helices, poly U, in the presence of the condensing agent 1-ethyl-3-(3-dimethylaminopropyl)carbodiimide, enhanced the coupling of adenosine 5'-phosphate with itself or with adenosine to 10% efficiency, generating primarily 5'-5' and 2'-5' internucleotide bonds.²⁴⁰ The importance of the template was shown by the lack of effect of polycytidylic acid on the condensation between adenosine nucleotides and of poly U on the formation of internucleotide bonds between adenylic acid and nucleosides other than adenosine.²⁸⁸

In an analogous manner, the self-condensation of guanosine 5'-phosphate and its coupling with guanosine was facilitated specifically by a polycytidylic acid template to give 6.9% dinucleotide, 18% pyrophosphate, and 2.8% trinucleotide.²⁸⁹ The relative effectiveness of poly U and an atactic polymer poly(1-vinyluracil) as templates for the condensation of adenosine 2',3'-O-cyclic phosphate with adenosine has also been examined.²⁹⁰ The efficiency of poly(1-vinyluracil) was lower than that of poly U under all conditions except at freezing temperatures when the binding with the template became more important than the rate of coupling.

The influence of a template on coupling can be expected to

TABLE II. Polymerization of Oligoinosine Derivatives on Poly C

Chain length $n = 6$ or 5	Polymerization of $(2'-\text{Melp})_6$ at 0°C for 15 days	% ratio of the products	
		Polymerization of $(2'-\text{Melp})_5$ At 0°C for 15 days and at -15°C for 28 days	At 0°C for 11 days and at 24°C for 4 days
$6n$		14.7	4.8
$5n$	9.2	11.2	5.8
$4n$	9.1	12.5	7.8
$3n$	13.2	12.7	9.1
$2n$	29.7	19.7	15.9
n	39.0	29.0	56.7

be more pronounced for a pair of short chains of nucleotides than for single units because of enhanced binding of oligonucleotides relative to mononucleotides. Uesegi and Ts'o²⁹¹ utilized hexa- $(2'-O\text{-methylinosine } 3'\text{-phosphate}) (2'-\text{Melp})_6$ and the corresponding pentamer $(2'-\text{Melp})_5$ as starting materials for water-soluble carbodiimide activated polymerization directed by a poly C template at low temperatures. From the results, summarized in Table II, the influence of the template in enhancing the yields of higher oligomers is apparent. The data regarding the polymerization of $(2'-\text{Melp})_5$ at different temperatures indicate the importance of the stability of the complex between the oligonucleotides and the complementary template in determining the extent of coupling.

The efficiency of the self-condensations brought about by water-soluble carbodiimides is often low (less than 10%) even in the presence of templates. To rationalize this, Badashkeeva et al.²⁹² showed the denaturing effect of reagents such as **192**

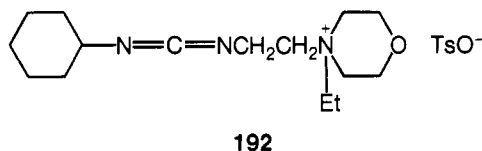

on the complex between the template and the substrate. They were able to obtain higher yields (26% dimer) by adding magnesium salts to stabilize the complex.

This difficulty has been partially circumvented by preactivating the phosphate moiety. For example, Orgel's group²⁹³ observed that adenosine 5'-phosphorimidazolide formed phosphodiester bonds on a poly U template to the extent of 50%. Prokof'ev et al.^{294,295} employed phenylalanine 5'-phosphoramidates of diadenylic acid and a poly U template; under conditions in which complex formation occurred, yields of oligo- and polyadenylates of around 10% were obtained.

C. Stepwise Synthesis in Solution

The nonspecific oligomerization procedures described above, although useful and interesting, offer no comfort to the chemist who seeks to emulate nature in the synthesis of nucleic acid macromolecules having a specifically defined primary structure. The brilliant studies of Khorana and his group over two decades, which recently culminated in the synthesis of a complete gene,^{9,10} represent a major milestone in nucleic acid chemistry. Such achievements in DNA chemistry have, as yet, no counterpart in the synthesis of large RNA molecules. The goal of a chemical synthesis of a complete *t*-RNA molecule is far from attainment.¹³

As illustrated below, the principles and strategies involved in the synthesis of ribo- and deoxyribooligonucleotides are strikingly similar. However, in addition to the problems encountered in the former series with selective protection of the 2'-hydroxyl, a major difficulty arises from the steric barrier imposed upon internucleotide bond formation by the replacement

of a hydrogen by a substituted oxygen moiety. Since no alternative to this arrangement has been or is likely to be found, the RNA synthetic chemist must seek ways to decrease the bulk of 2'-hydroxyl blocking groups and to increase the efficiency of internucleotide bond formation to the greatest extent possible.

The stepwise approach (as opposed to block condensation) to oligonucleotide synthesis has been and is today the most frequently used method. This is true for three reasons: (i) the yields of individual condensations tend to be relatively high (40–95%); (ii) it is only by the stepwise approach that the oligonucleotide blocks may be prepared; and (iii) most of the studies hitherto reported (particularly in the ribose series) are designed for methodological development and are much more readily carried out at the di-, tri-, or tetranucleotide level.

The primary disadvantages to the stepwise approach are the decrease in coupling yield with increasing chain length and the difficulty in separating the product and the starting oligonucleotides differing in molecular weight by only one nucleotide. In addition, a maximum number of coupling steps to the desired goal is required. These problems are largely overcome by linking preformed oligonucleotide blocks; but the usual yields of such condensations are quite low. The exception is found in the DNA series in cases when a template complementary to the blocks to be connected is available and the enzyme DNA ligase^{295–301} may be used to effect the linkage.^{302–306} Since at the present time no "RNA ligase" is available, the method is not applicable to coupling of oligoribonucleotides. In any event a discussion of enzymatic methods (which encompass polynucleotide phosphorylase from *E. coli*^{307–310} and terminal deoxynucleotidyl transferase^{311–314} in the deoxy series, and polynucleotide phosphorylase,^{315–320} specific^{321–337} and nonspecific^{338–368} ribonucleases in the ribo series) for oligo- and polynucleotide synthesis lies beyond the scope of this review.

Two types of condensation resulting in joining two nucleotide residues may be visualized depending on the origin of the phosphate function. In the type 1 condensation, a 5'-nucleotide (**59** and **67**) is coupled with a free 3'-hydroxyl function of properly protected **58** or **66**. The type 2 condensation is the opposite; i.e., a 3'-phosphate (**61** or **63**) is condensed with a 5'-hydroxyl (**62** or **64**). Few studies designed for direct comparison of these two strategies have appeared, although it has been reported³⁶⁹ that similar yields for uridyl-3'-5'-uridine were obtained by each approach. As a general statement, however, the type 1 condensations are most applicable in the less hindered 2'-deoxy derivatives, whereas condensations involving 3'-phosphate and 5'-primary alcohol groups (type 2) are applicable to both ribo- and deoxyribonucleotides.

1. Type 1 Condensations

This type of reaction has been extensively studied by Khorana and his associates^{12,370–373} in their syntheses of oligo- and polydeoxyribonucleotides. An oligonucleotide chain or a single nucleoside bearing an acid-labile monomethoxytrityl group or protected phosphate moiety (see also section V.D.1) at its 5' end is lengthened in two steps (Scheme XVIII). This strategy of building from the 5' end to the other is extremely popular^{175,374} in the deoxy series because of the well-established routes for preparing the key intermediates and of its applicability to longer chains.

It is intuitively obvious that the methodology illustrated in Scheme XVIII is directly applicable to ribonucleosides (*-tides*) carrying an acid-labile 2'-hydroxyl masking group. As is often the case with intuitively satisfying "paper chemistry", the actual application of the technique has proved rather disappointing. The difficulties encountered result largely from steric hindrance by the 2'-substituent to the approach of 5'-phosphate, usually carrying a bulky activating group, to the 3'-hydroxyl function.

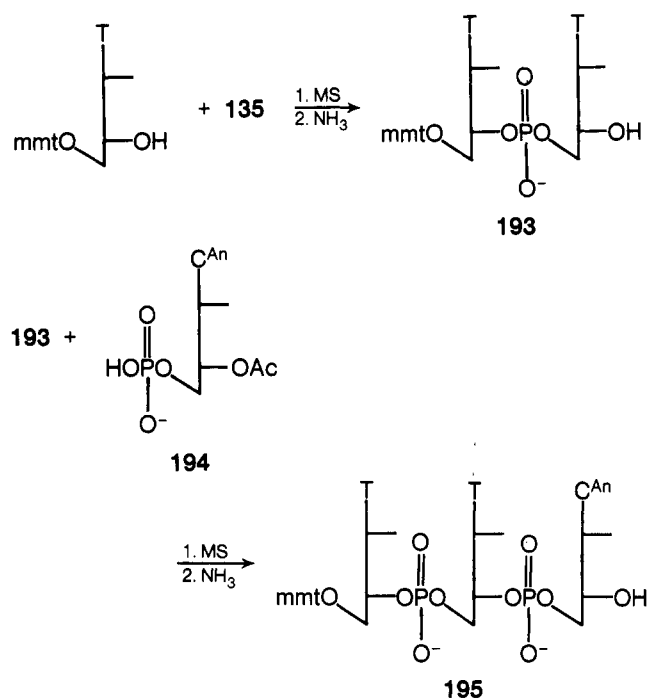
SCHEME XVIII³⁷¹

Although a variety of type 1 approaches have been reported, notably by Reese,^{22,29,30,89,103,375} synthesis beyond the dinucleotide level has not been accomplished.³⁷⁶⁻³⁷⁸ The synthesis of various diribonucleotides in reasonable yields (50–70%) by this route,^{376,377} as illustrated for **198**, may be of use in preparing intermediates for block synthesis.

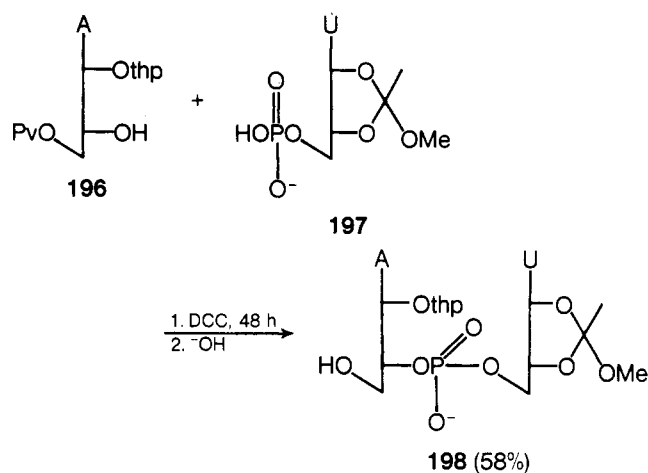

2. Type 2 Condensations

Condensations between a 3'-nucleotide and the 5'-hydroxyl of a nucleoside (type 2) represent the most common approach to the synthesis of oligoribonucleotides (Scheme XIX).³⁷⁹ In the 2'-deoxy series, however, the substantially greater availability of 5'-nucleotides than 3'-phosphates has encouraged the type 1 coupling described above. In the type 2 approach, both diester and triester condensations have been extensively utilized.

a. Phosphodiester Method

Pioneering work by Khorana,^{20,38,80,267,380,381} Hall,¹⁸ Holy and Smrt,¹⁰² and Cramer^{52,53,382} laid the foundation for this productive method. Basically, a 3'-nucleotide is added to 5'-hydroxyl at the growing end. The protecting group at the 5' end of the chain is released after each condensation under conditions to which 2'-hydroxyl and 2',3'-*cis*-glycol blocking agents are insensitive. The synthetic scheme involving the acid-labile 5'-

SCHEME XIX

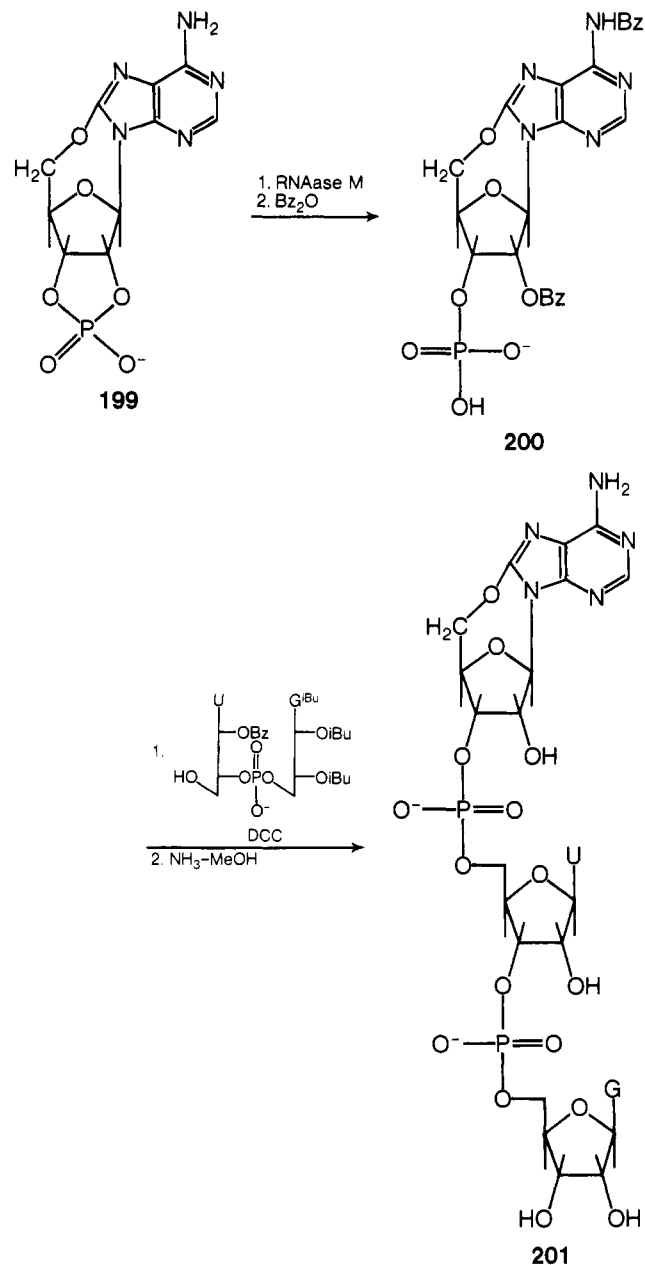

O-monomethoxytrityl moiety was used by Khorana for the preparation of all the 64 possible ribotrimer nucleotides assembled from the four common ribonucleotides³⁸³ (Scheme XX). The first step is the condensation of a 2'-*O*-acyl-5'-*O*-monomethoxy-

SCHEME XX

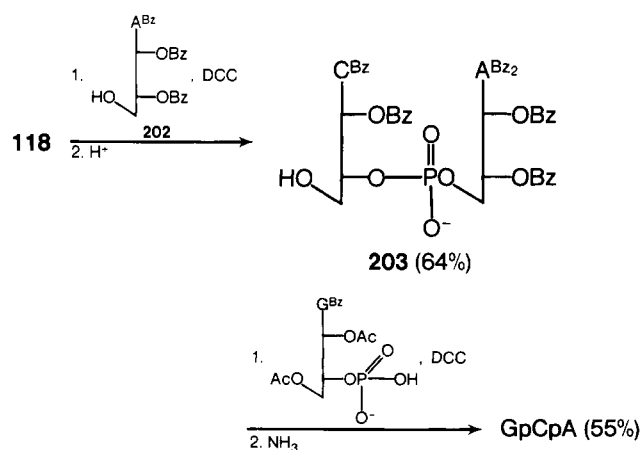

SCHEME XXI

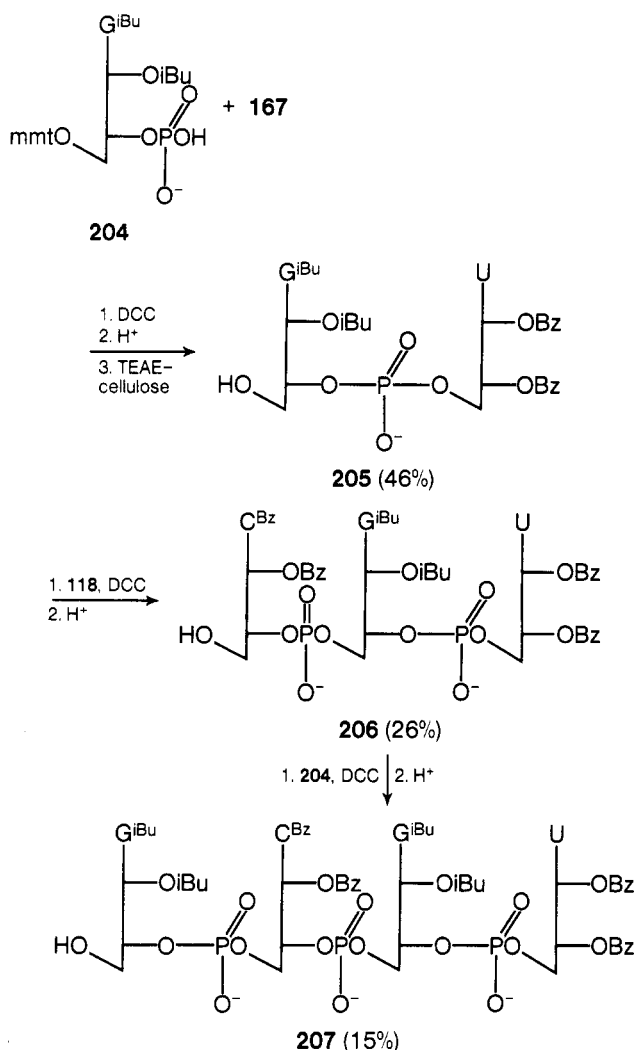

trityl-3'-nucleotide (118) with the 2',3'-di-*O*-acylnucleoside (202). Acidic workup of the reaction mixture yields the diribonucleoside monophosphate 203 with a free 5'-hydroxyl function while the acyl groups remain intact on all other sensitive functions. In principle these two steps may be repeated to a desired goal; in practice the yields fall off fairly sharply with each addition.

This approach requires the isolation of intermediate compounds in neutral or weakly acidic media and at low temperature. The difficulty of carrying out acylation of a 3'-nucleotide on a large scale and the multistep procedures required for the synthesis of 2',3'-di-*O*-acyl nucleosides such as 202 are drawbacks to this approach. The latter disadvantage may be overcome by blocking 2',3'-hydroxyls by acid-stable groups, such as the carbonate moiety, which are specific for the cis-diol system. Despite the disadvantages, preparative routes to the necessary intermediates worked out by Khorana have enabled Ikehara's group^{13,44} to employ this approach to make short segments of ribonucleotides which were parts of yeast alanine *t*-RNA (Scheme XXI).³⁸⁴

Since many common protecting groups for the 2'-hydroxyl and 2',3'-cis-diol functions are acid labile, base-sensitive blocking agents at 5'-O site were evaluated by Holy, Smrt, and their co-workers^{16,92,102,385,386} and Cramer.^{53,54,382} An example of this strategy, which also progresses from the 3' end of the chain, was provided in Scheme I. This method may find use in making tri- or tetra-ribonucleotides for block synthesis (vide infra).

One prominent shortcoming of the diester method is the time-consuming separation of the starting and the product oligonucleotides. The need for more rapid methods for isolation

SCHEME XXII

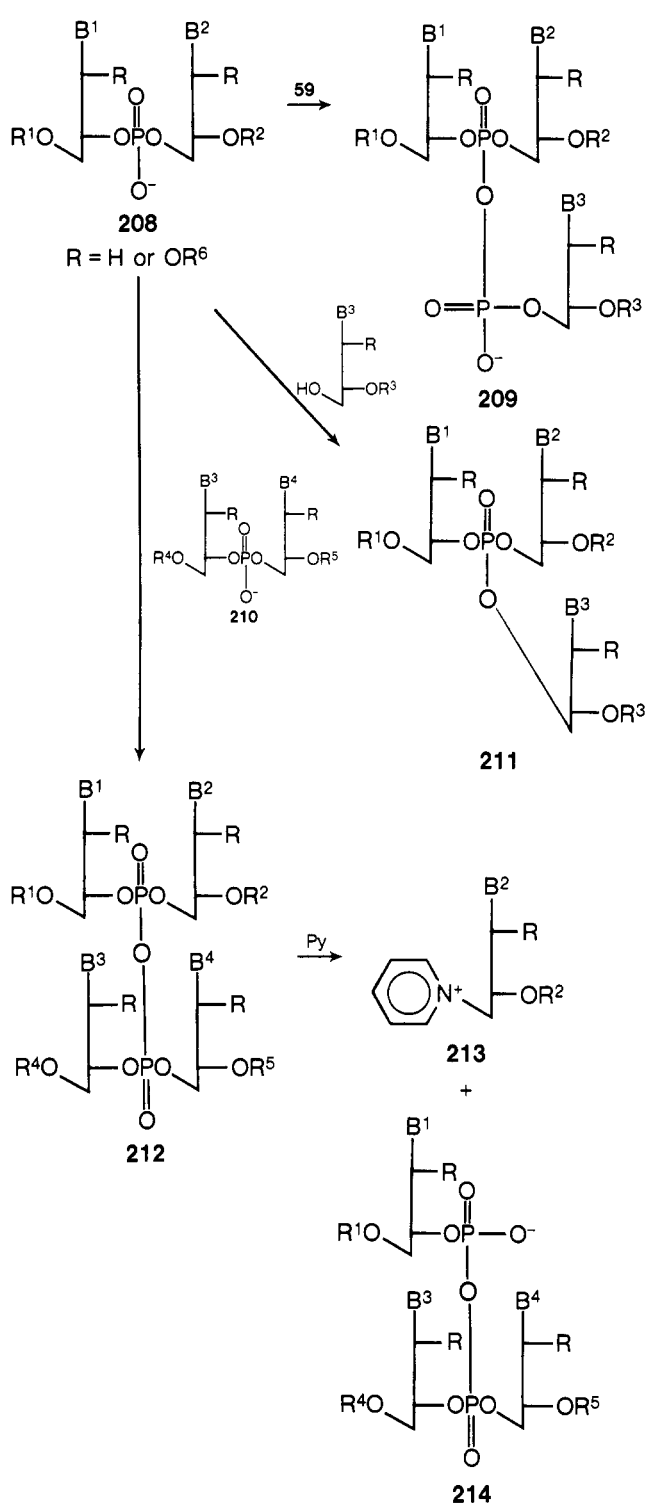

and characterization of oligonucleotides has encouraged considerable investigation in the applications of various separation techniques and tools to these compounds.

Retaining the often used DEAE-cellulose,³⁸⁷ Koster and Kaiser³⁸⁸ employed alcohols or mixtures of alcohols with ionic strength gradients of appropriate steepness for elution. Identification, estimation, and separation of mixtures of oligothymidylates as well as mononucleosides and nucleotides were shown to be possible by thin-layer chromatography on Avicel-cellulose plates.³⁸⁹ Egan successfully separated oligo- and oligodeoxyribonucleotides^{390,391} by reversed phase chromatography on columns of polychlorotrifluoroethylene support coated with methyltrialkylammonium chloride using ammonium acetate el-

uents. Purification based on the varied affinities between a mixture of oligonucleotides and nucleotide chains of known length and sequence immobilized on a cellulose column has been investigated.³⁹²⁻³⁹⁶ For example, a mixture of hexa-, hepta-, octa-, and nonaadenylic acids was resolved by a column of cellulose-p(dT)₉. Cook et al. recently have reported³⁹⁷ an application of high-pressure liquid chromatography (HPLC) for resolving oligodeoxyribonucleotides of intermediate size.

b. Triester Method

In the synthesis of long oligonucleotides by the diester method, undesired side reactions have been encountered resulting from activation of the unprotected phosphodiester functions and subsequent displacement at phosphorus by available nucleophiles (Scheme XXII).^{44,160,398,399} Such side reactions increase in probability with increasing chain length; they compete appreciably with the slower condensations found in the ribo series. Protection of the phosphodiester residues has been shown to be a successful solution to this problem. The ability to purify the resulting triester derivatives on silica gel, which has higher capacity and faster flow rate than DEAE-cellulose, is an additional advantage, one which will be compounded by the application of HPLC techniques.

The common practice has been to have the diester, for example, **215**, as one of the components for a TPS activated

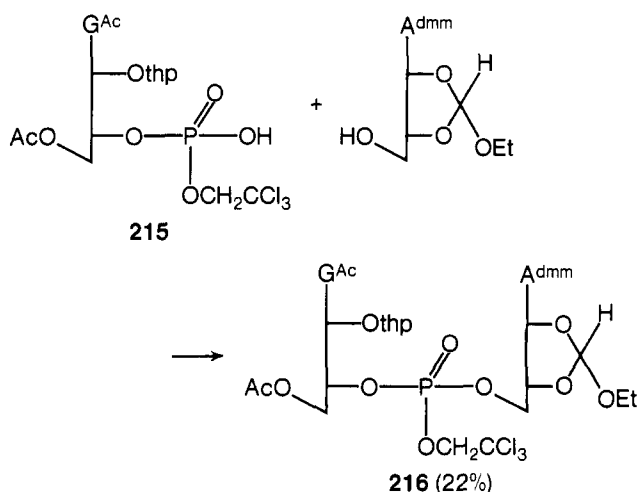

condensation. Although pyrophosphate formation is essentially prevented, the rate of internucleotide bond formation is lowered by a factor of 10.⁴⁰⁰ Hence the reaction period is usually prolonged (2 to 6 days). An interesting report⁴⁰¹ evaluating the method for oligodeoxyribonucleotide synthesis revealed that the presence of a 5'-phosphate triester unexpectedly stabilized the 3'-O-acetyl group such that its removal caused some deprotection of amino groups on the bases. This sort of observation, coupled with increase in reaction times, has inhibited extensive application of the triester approach in the deoxy series.

In the synthesis of oligoribonucleotides the isolated yields of trinucleoside diphosphates from dinucleotides by the diester method rarely exceeds 25%. The triester method, by eliminating some of the side reactions, has been found to improve the yields of the tri- and tetranucleotides considerably.³⁹⁹ Therefore this approach has gained increasing application in the synthesis of oligoribonucleotides.

The choice among 2,2,2-trichloroethyl, 2-cyanoethyl, and phenyl or substituted-phenyl moieties much depends on the nature of other protective groups. When the synthesis and isolation of the phosphate protected derivatives are carried out in alkaline solution, 2,2,2-trichloroethyl blocking is appropriate,^{24,85,157,159,402} although its removal from long chains is not always satisfactory.⁴⁰⁰ The 2-cyanoethyl group is well suit-

ed^{87,163} to most other conditions. Phenyl and substituted-phenyl groups^{31,145,164} are less commonly used.

The general approach has been to phosphorylate a nucleoside derivative at the 3' position with a phosphate monoester and to activate the resulting diester before reaction with the 5'-hydroxyl residue of another nucleoside. In the deoxy series it is necessary to have a 3'-blocked nucleoside in order to prevent the formation of 3'-3' linkage; for example, condensation of **217a** with **218a** led to 4% of the 3'-3' isomer of **219a**.¹⁶³ The 2'-O-tetrahydropyranyl moiety, on the contrary, hindered the cis 3'-hydroxyl of uridine (**218b**) sufficiently that no prior protection of the latter was required.⁴⁰² The distinction is important because a blocking-deblocking sequence is eliminated with each chain extension step.

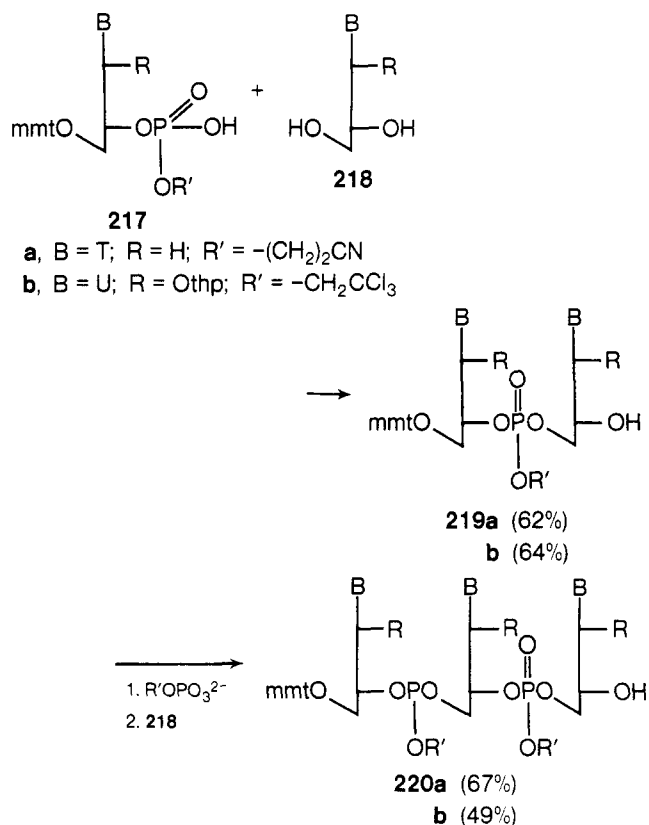

Ideally, it would be highly desirable to combine the relatively high reaction rate of the phosphodiester approach with the convenience of isolation of the triester method. Smrt has described in a recent series of papers⁴⁰³⁻⁴⁰⁶ just such methodology. A typical condensation between a 3'-mononucleotide (**221**) and a nucleoside (**222**) bearing a free 5'-hydroxyl is followed by reaction of the resulting diester with 2-cyanoethanol in situ. The

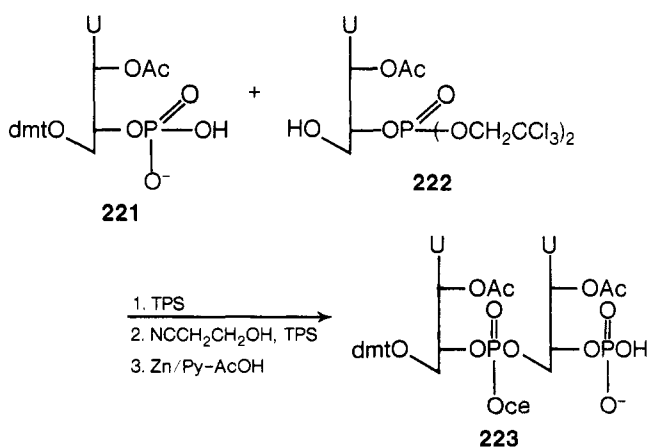

SCHEME XXIII

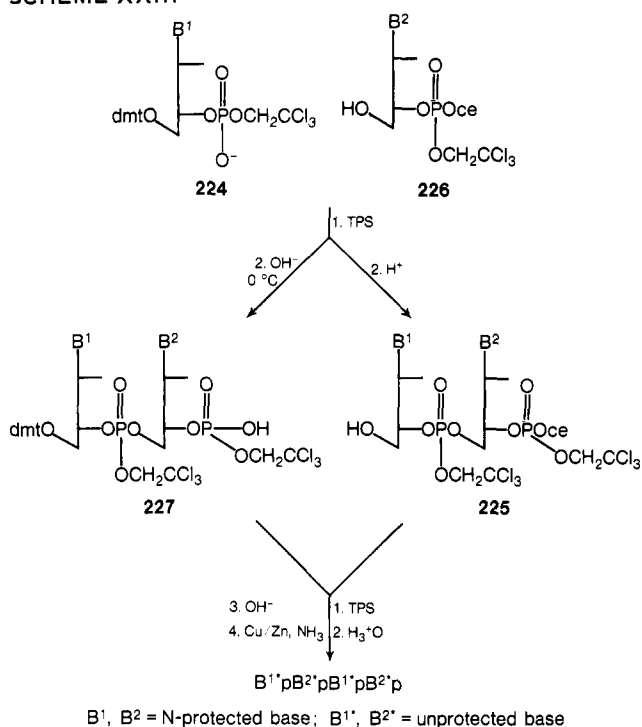

triester product is purified by silica gel chromatography; the yields are markedly enhanced.

The synthetic sequences so far discussed have also been used for the preparation of oligonucleotides incorporating modified nucleotides, which encompass modified bases,⁴⁰⁷⁻⁴¹⁷ anhydronucleosides,^{379,418-424} isomeric sugar moieties,⁴²⁵⁻⁴²⁷ and internucleotide linkages other than the phosphodiester bond.⁴²⁸⁻⁴⁴⁰

D. Block Synthesis in Solution

1. Oligonucleotides with Terminal Phosphate Groups

Oligonucleotides carrying a phosphate residue at the 5' end (as in natural polynucleotides) or at the 3' end are the requisite building units for block synthesis. Since initial experiments on phosphorylation of oligonucleotides gave low yields,⁴⁴¹ the tendency has been to use a protected nucleoside 5'- or 3'-phosphodiester as the phosphate terminal unit. The various phosphate blocking agents available for this purpose were discussed in section III.B.2. Direct phosphorylation of a 3'-*O*-acetyldi(deoxyribonucleoside) monophosphate with phosphorus oxychloride has been reported recently.⁴⁴²

It is obvious from the discussion of the diester and triester approaches that phosphomonoesters are more reactive in condensations than phosphodiesters; the triesters are, of course, unreactive. In condensations of two nucleotides, one of which is to bear the 3'(5')-terminal phosphate, the terminal group may be a diester if the incipient internucleotide phosphate is a monoester (**136** and **139**). If the coupling is to lead directly to a triester, however, the terminal phosphate must be protected as a triester (Scheme XXIII). In such a case, the terminal triester may bear the same⁴⁴³ (**222**) or different^{166,232,401} (**226** and **227**) protecting groups, depending on whether chain termination or elongation is planned. Alternatively, the terminal phosphate may be added to the product of condensation with reagents such as phenyl phosphate¹⁶⁵ or 2,2,2-trichloroethyl phosphate.⁴⁴⁴ For example, Neilson et al.⁴⁴⁴ phosphorylated the 5' position of various protected di- and trinucleotides with TPS activated trichloroethyl phosphate followed by deblocking in good yields (57-70%).

SCHEME XXIV

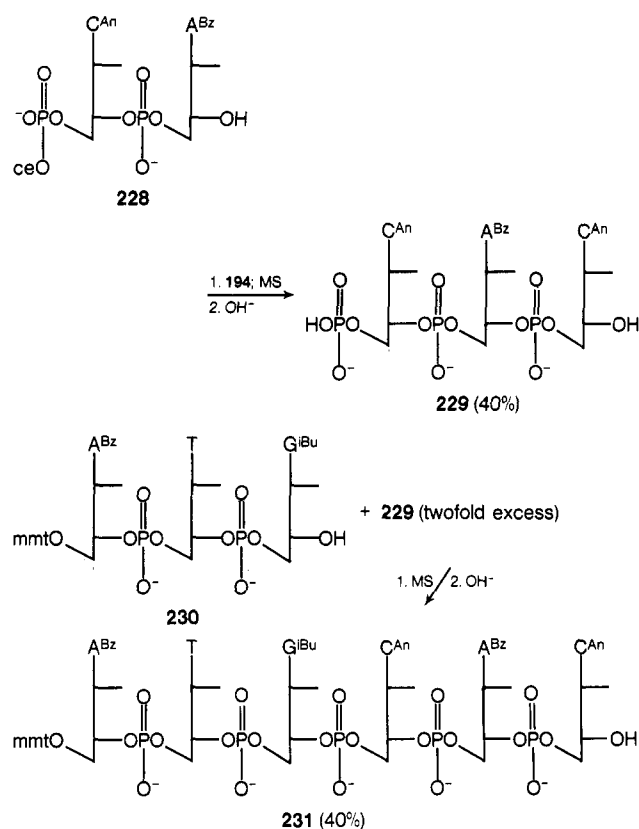

2. Joining the Blocks

The condensation of preformed blocks to provide longer oligonucleotides shortens the number of steps toward the target compound and simplifies the isolation of the product. Oligonucleotide units carrying terminal phosphate residues are required for this approach; they offer the flexibility of chain extension at either end through selective blocking or deblocking.

In the deoxy series Khorana attempted block synthesis as early as 1962 with limited success.^{160,162,445} His later experiments,^{82,446,447} which centered around type 1 condensation (Scheme XXIV),⁴⁴⁸ led to the following deductions: (i) the rate of condensation between two blocks was lower than that for the addition of a single nucleotide; (ii) the yield decreased with increase in chain length, which was compensated for by increasing the excess of the nucleotide component (**229**); and (iii) although a large excess of condensing agent tended to increase the yield of coupling, its interaction with the preformed phosphodiester bonds caused undesirable side reactions. The loss due to side reactions was minimal when MS was used in limited excess (0.6 molar equiv of total molar equivalents of phosphodiester groupings in both chains) and especially when the reaction period was reduced to less than 4 h.⁴⁴⁹ The components were usually introduced as their trialkylammonium salts to enhance their solubility in absolute pyridine.

Synthetic routes to deoxyribooligonucleotides employing reactions similar to Scheme XXIV have been extensively exploited with only slight modifications (ref 176-178, 216, 217, 450-467). The choice of oligonucleotide blocks depends on various factors; for example, the coupling of a purine nucleotide to another is avoided because of low yields. The size and total anionic charge of the fragments play dominant roles in product separation, which is most efficient when the component units are of equal size.⁴⁵⁷ For example, the condensation between **232** and **233** or between **234** and **235**⁴⁶⁰ was followed by chromatography on benzoylated DEAE-cellulose; **232** and **234** were preferentially retained by virtue of the aromatic protecting

groups. Since products and reactants differ in molecular weight substantially, they were separated by gel filtration.⁴⁵⁷

Block synthesis involving oligoribonucleotides has been pursued only recently because of the difficulties involved in obtaining the requisite starting materials. Ikehara's group coupled diester intermediates (Scheme XXI) and encountered all the disadvantages of the diester method.^{13,44,384} The yields were

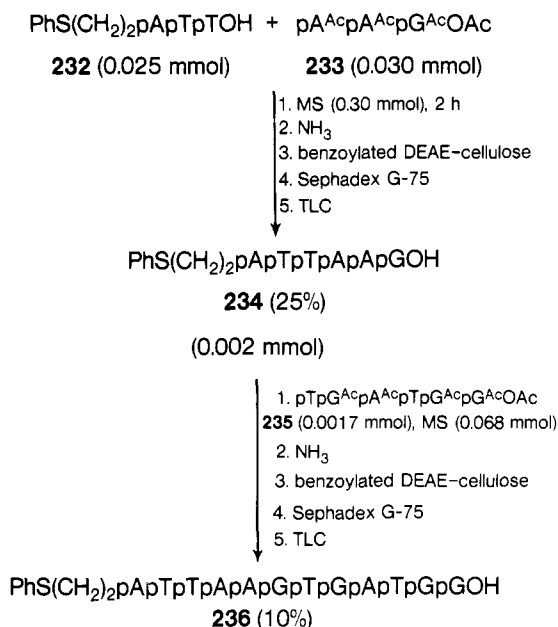

low; reaction of a trinucleotide with another trinucleotide⁴⁴ and with a hexanucleotide³⁸⁴ gave only 18 and 8% yields, respectively. The results were more respectable for Neilson's triester approach⁹⁷ to the synthesis of a nonaribonucleotide (Scheme XXV).¹¹ As a result of continuing improvement in the methods of internucleotide bond formation,²⁴⁵ this pathway is expected to dominate oligoribonucleotide synthesis.

E. Synthesis on a Polymer Support

Separation of oligonucleotides from other reagents at the end of coupling is usually a laborious and time-consuming process. If the starting nucleoside, nucleotide, or even a small chain of nucleotides is joined covalently to a polymer support and subsequent nucleotide units are added stepwise, major purification may be attained simply by filtering the polymer-supported oligonucleotide and washing away other soluble by-products and excess reagents. At the end of the synthesis the polymer may conveniently be removed to yield the product. This concept, introduced by Merrifield, has been quite successful in the synthesis of peptides and enzymes.⁴⁶⁸ The successful application of the concept to nucleotide field depends on certain requirements which are elaborated below.

The salient information regarding the polymer supports used for oligonucleotide synthesis is displayed in Table III. The diester method has been investigated almost exclusively in conjunction with polymer carriers. It is likely that difficulties arising from the presence of ionic phosphodiester moieties in proximity to a nonpolar support may be alleviated by application of the triester method.⁴⁶⁹

1. Preparation of the Polymer Supports

The polymer supports should be easily prepared and must possess an adequate number of reactive sites. Most of the polymers of Table III were prepared with no great difficulty except, perhaps, isotactic crystalline polystyrene carriers.⁴⁷⁰ Reactive functions are usually introduced onto a polymer by common organic reactions. An excellent illustration is the

SCHEME XXV

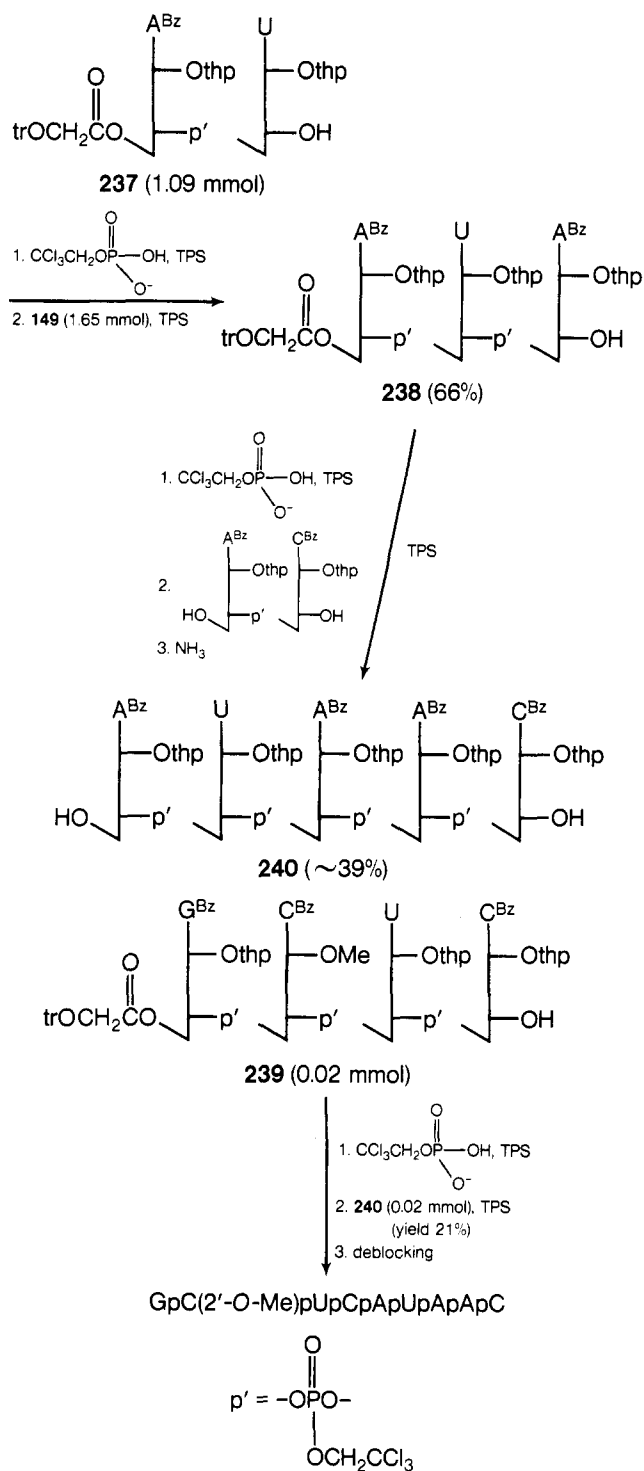

preparation of polystyrene supported 2-pyridineethanol⁴⁷¹ (Scheme XXVI). One problem often encountered in such reactions is the low efficiency of incorporation of the functional sites on the polymer⁴⁷⁰ (especially for highly cross-linked and crystalline polymers), thereby making preparative-scale synthesis (100 mg or larger) very difficult. Synthesis of copolymers carrying the reactive group or its immediate precursor reduces the number of reactions that must be applied to the support and frequently gives a direct measure of the number of active centers per unit weight of polymer.⁴⁷²⁻⁴⁷⁴ Certain polymers such as polyvinyl alcohol⁴⁷⁵ and cellulose⁴⁷⁶ have intrinsic active centers. In any case, after the carrier has been charged with the initial nucleoside (-tide), all other unreacted functions must be blocked prior to oligonucleotide synthesis.^{272,477}

TABLE III. Polymer Supports for Oligonucleotide Synthesis

Item no.	Ref	Polymer type	Active group	Loading mmol/g of polymer or % ^a	Attachment μ mol/g of polymer or % ^b	Yield of internucleotide bond formation, % ^c				
						I	II	III	IV	V
Insoluble Polymers										
1	472 473 486 487	Styrene popcorn copolymer with about 0.1% cross-linking	$\text{P-C}_6\text{H}_4\text{COCl}$	11–12%	40–60%	72	76			
2	482	Popcorn styrene copolymer with 0.2% di- vinylbenzene	P-dmtCl	0.7–1.0 13.3%	35–50%	64	64			
3	480 481	Polystyrene with 0.75–1.0% cross-linking	P-mmmtCl	9%	70–80%	71	79	51	37	
4	481	1–2% divinylbenzene–styrene copolymer	$\text{P-C}_6\text{H}_4\text{CH}_2\text{OmmtCl}$	1.7–2	~90%	59	52	39	49	
5	484	Bead styrene–divinylbenzene (2%) copoly- mer	$\text{P-C}_6\text{H}_4\text{CH}_2\text{OC}_6\text{H}_4\text{NH}_2$	11%	60–80%	40	13			
6	511	Bead styrene–divinylbenzene (2%) copoly- mer	$\text{P-C}_5\text{H}_4\text{CH}_2\text{OC}_6\text{H}_4\text{NH}_2$	1.19	8%	38	10 ^d			
7	514	Porous styrene–divinylbenzene copolymer	$\text{P-C}_6\text{H}_4\text{CO}(\text{CH}_2)_2\text{CO}_2\text{H}$			38	25			
8	108	Isotactic polystyrene	$\text{P-C}_6\text{H}_4\text{CO}(\text{CH}_2)_2\text{CO}_2\text{H}$	16%	80%	50	50 ^e			
9	470	Isotactic polystyrene cross-linked with di- vinylbenzene	P-mmmtCl	0.1–0.4				28		
10	495	Highly cross-linked macroporous polysty- rene	P-mmmtCl		4.65	73	66			
11	471	6% cross-linked macroporous polystyrene	243	20%		35	50	78	33	38
12	477	5% cross-linked macroporous polystyrene	$\text{P-C}_6\text{H}_4\text{CH}_2\text{Cl}$	0.75	175–270	39	25	19	21	
13	493 494	Highly porous nonswellable copolymer of styrene and 33% divinylbenzene	P-mmmtCl and P-dmtCl	5–8%	40–60%	49			37 ^f	
14	505	Poly-L-lysine with 2.4 mol % cross-linking	$\text{P-NHCOC}_6\text{H}_4\text{NH}_2$	61%				43		
15	503	Silica gel	P-Si-trCl	0.19	6%	54				
Soluble Polymers										
16	496	Polystyrene (mol wt 270 000)	P-mmmtCl	5%	15%	96	87			
17	497	Polystyrene (mol wt 170 000)	P-mmmtCl	20%	40%	91	62			
18	475	Polyvinyl alcohol (mol wt 70 000)	P-OH			26	41	10	8	14
19	501	Diaminopoly(ethylene glycol) (mol wt 10 000)	P-NH_2			60	40 ^g			
20	498	Poly(ethylene glycol)	P-OmmtCl		28.7					
21	272 500	Hydrolyzed copolymer of vinyl acetate and N-vinylpyrrolidone	P-NH_2	1	110					

^a Loading refers to the extent of polymer sites reacted to contain the active groups, in mmol of functional groups/g of polymer unless indicated in percent.

^b The amount of nucleotide material in μ mol anchored to a gram of polymer or the percent of active groups carrying the chain initiator. ^c The yields are for the chain elongation step (indicated by the number) during the synthesis of oligothymidylates except noted otherwise. I is the yield of dimer from monomer, II the yield of trimer from dimer, etc. ^d For the synthesis of ApUpGp. ^e For the synthesis of UpUpU. ^f For block synthesis using dinucleotide fragments.

^g For the synthesis of d-pA^{Bz}pA^{Bz}pA^{Bz}.

SCHEME XXVI

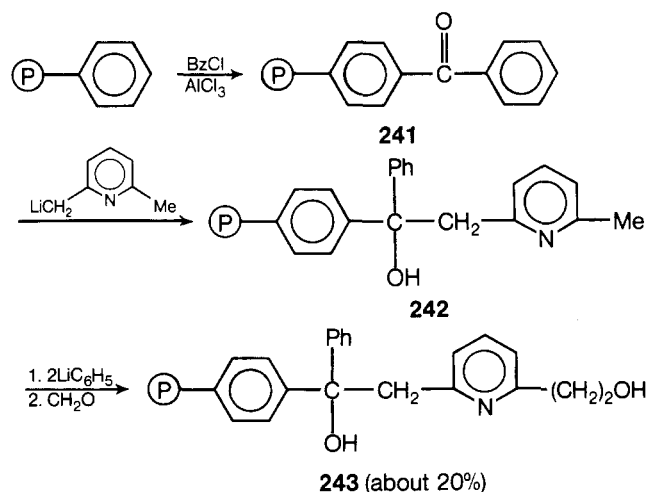

2. Ease of Handling

The main reason for using a polymer support carrying nucleotide chains—clean and convenient separation from the reaction mixture—can also serve as criterion for ease of handling. Most of the carriers currently in use are polystyrene based

copolymers; their aromatic character makes them stable to the conditions used in synthesis and provides a handle for the introduction of required functional groups.

The available supports may be considered in three broad categories: insoluble (swelling), insoluble (nonswelling), and soluble. The insoluble polystyrene-type polymers with a low degree of cross-linking^{472,473,478–488} swell to different extents in various solvents, thus sharply limiting the choice of solvents and conditions for purification. Insoluble polymers with high cross-linking,^{489–495} particularly in bead form,⁴⁹¹ and crystalline isotactic polymers¹⁰⁸ do not swell. They may be recovered completely and purified easily by washing.

Soluble supports may be low molecular weight functionalized polystyrenes^{496,497} which are soluble in pyridine but not in water, alcohol, or ether. These basically hydrophobic chains, when loaded with hydrophilic oligonucleotides, are not completely recovered (10–15% loss with each extension step) by salting out techniques.⁴⁹⁶ This approach has given way to many polymer carriers^{272,475,498–502} which are soluble in water, pyridine, and possibly other solvents. Seliger and Aumann²⁷² have recently suggested the use of modern techniques such as dialysis, ultracentrifugation, and Sephadex chromatography for overcoming the problem of separation and purification of the soluble supports from low molecular weight compounds.

In order to eliminate the incompatibility of the nonpolar

polymers and the increasing number of strongly polar phosphodiester bonds, a few polar carriers have been investigated, including cellulose,⁴⁷⁶ silica gel,⁵⁰³ polysaccharide,⁵⁰⁴ polypeptide,⁵⁰⁵ poly(ethylene glycol),⁵⁰⁶ and macroreticular partially hydrolyzed poly(vinyl acetate)⁵⁰⁷ supports. Synthesis directed by a polymer supported polynucleotide has also been suggested.⁵⁰⁸

3. Attachment to and Removal from the Polymer Support

The covalent attachment of the nucleoside or nucleotide chain initiator to the polymer and the subsequent release of the oligonucleotide chain must be easily and efficiently brought about under conditions to which other bonds in the system are stable. The nucleotide functional group selected for attachment to the polymer has often been 5'-hydroxyl, although the amino group on the base,^{473,509} 5'-phosphate,^{471,475,484,501,510} 3'-phosphate,⁵¹¹ 3'-hydroxyl,⁴⁸⁶ and 5'-thiophosphate⁴⁷⁷ functions have served the same purpose.

The selectivity of removal in most of the reported carriers has not been satisfactorily demonstrated in the synthesis of complex oligonucleotides. On the basis of the sensitivity of phosphoramidates to fairly mild conditions of isoamyl nitrite in pyridine-acetic acid buffer Ohtsuka et al.⁵¹¹ synthesized ApUpGp (Scheme XXVII). In many other cases, however, acidic or basic conditions employed for breaking the polymer-oligonucleotide linkage have led to depurination or loss of acyl protecting groups. The new *o*-nitrobenzyl resin⁵¹² (**248**), which may be released by photolysis, seems to be a welcome addition to the list of polymers, although its application in oligonucleotide chemistry has yet to be demonstrated.

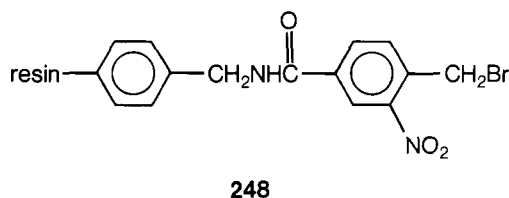

4. The Yield at the Coupling Step

One severe limitation of the polymer support approach to specific oligomer synthesis is the formation of truncated and failure sequences.⁵¹³ The former represents sequences with one or more missing units at the growing end, while the latter include sequences in which units are missing from anywhere within the chain (Scheme XXVIII). Identification and isolation of the required sequence from a mixture are very difficult, especially if the target chain is very long. The formation of truncated (**250** and **252**) and failure (**253** through **256**) sequences may be eliminated only by quantitative linking of each unit, a goal unattainable in practice. It is feasible to keep failure sequences very low by blocking the unreacted growing end after each internucleotide bond formation (as in Scheme IX), but the only method for reducing the number of truncated sequences is to improve the yield of condensation reaction. In general, the yield of phosphodiester bond formation seems to increase by shifting from insoluble to soluble supports,^{496,497} from highly cross-linked to macroporous polymers^{473,482,488,514} and from too small or too large a degree of loading to an optimum level.

A recent development, which illustrates the potential of polymer-supported synthesis, came from the laboratory of Koster.^{493,494} Addition of both mono- and dinucleotides to a growing chain anchored to a porous copolymer (Scheme XXIX) gave an impressive yield of the target heptanucleotide **260**.

It is clear that the "ideal polymer" for the support of oligonucleotide synthesis has yet to be found. A thorough and systematic study utilizing the extensive body of data provided in

SCHEME XXVII

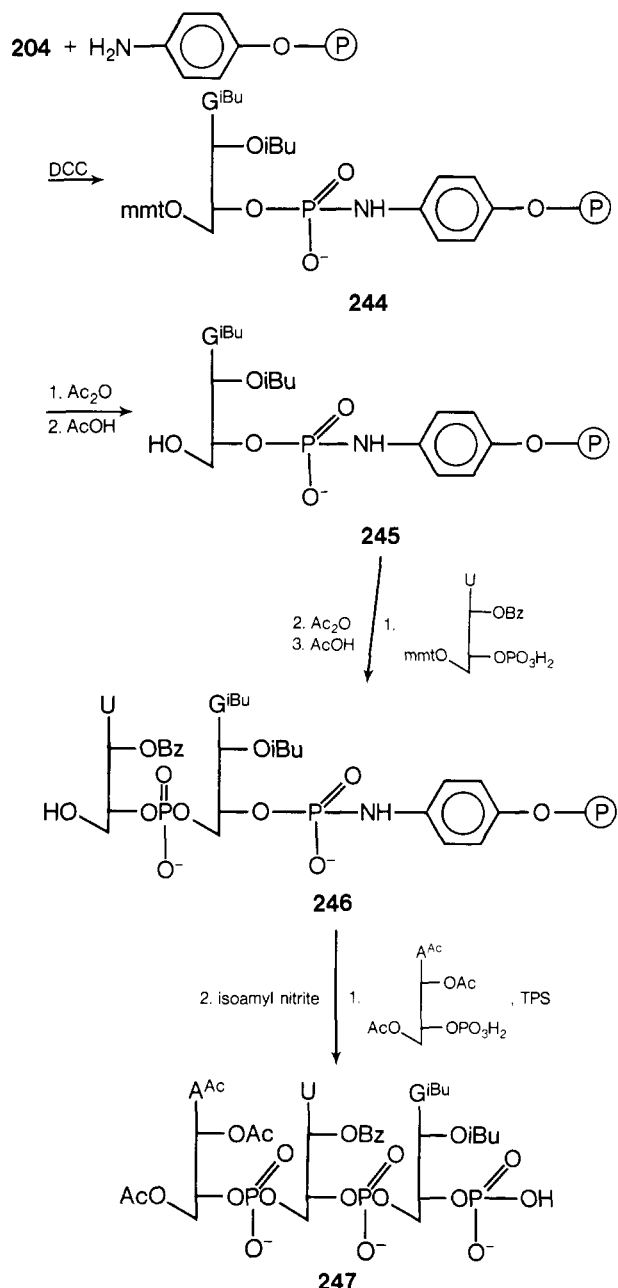

Table III should be undertaken in order that the promise of substantial savings in time and effort in the preparative synthesis of oligonucleotides may be realized.

VI. Conclusion

Chemical methods for the synthesis of oligonucleotides have undergone dramatic improvement in the last two decades, but such goals as the synthesis of a *t*-RNA molecule or the facile preparative synthesis of DNA genes still shimmer in the distance. A recent publication from Khorana's laboratory,⁵¹⁵ describing a new computer program (DINASYN) designed to minimize the time required for synthesis, reports that the combined enzymatic and chemical synthesis of the gene for yeast alanine *t*-RNA required 20 man-years of effort. The minimum time which resulted from a computer determination for the optimal path to the two complementary 75 nucleotide chains was still 11 man-years. We have a long way to go.

VII. Appendix

Among the new papers⁵¹⁶⁻⁵⁶⁵ published during the past year,

SCHEME XXVIII

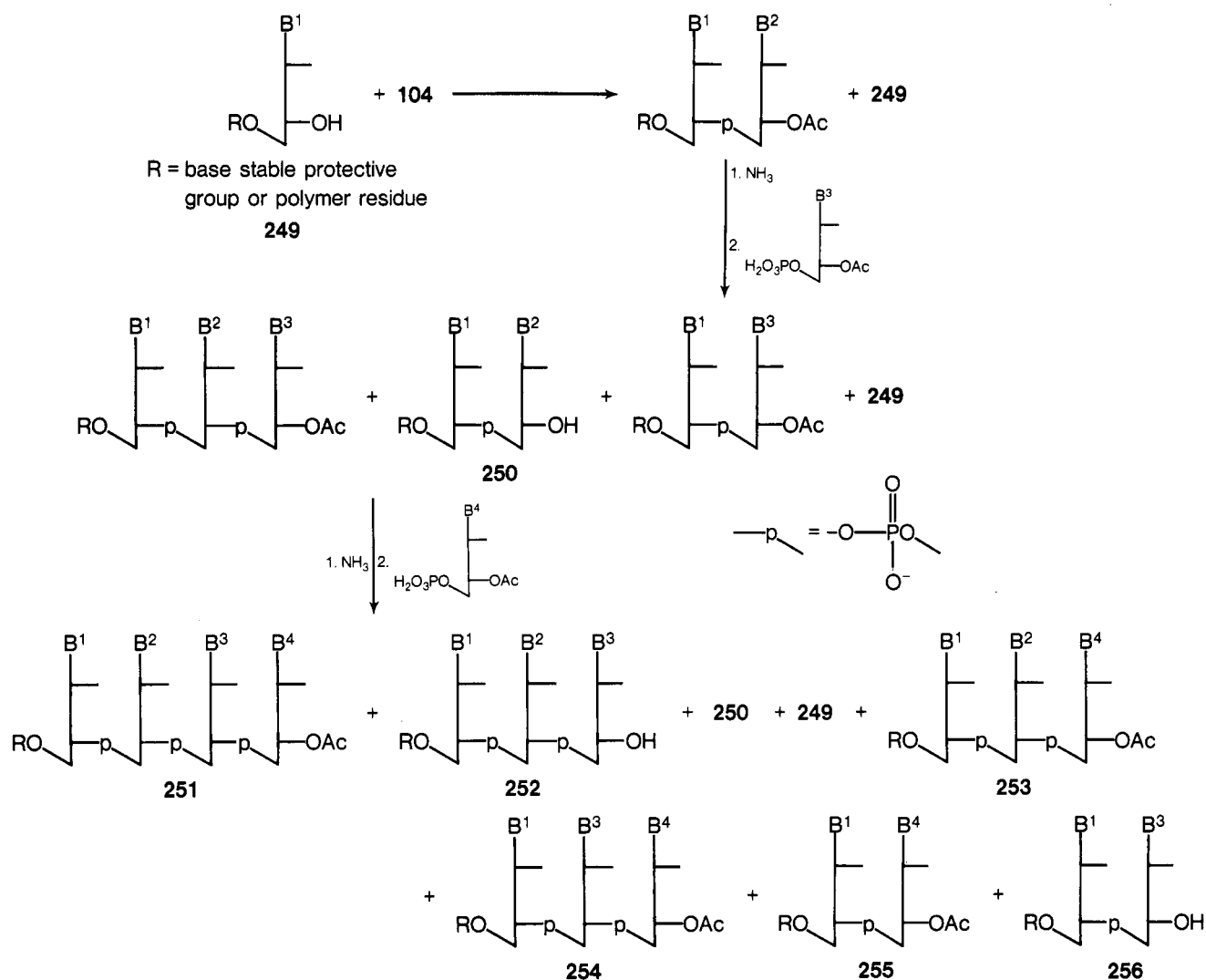

SCHEME XXIX

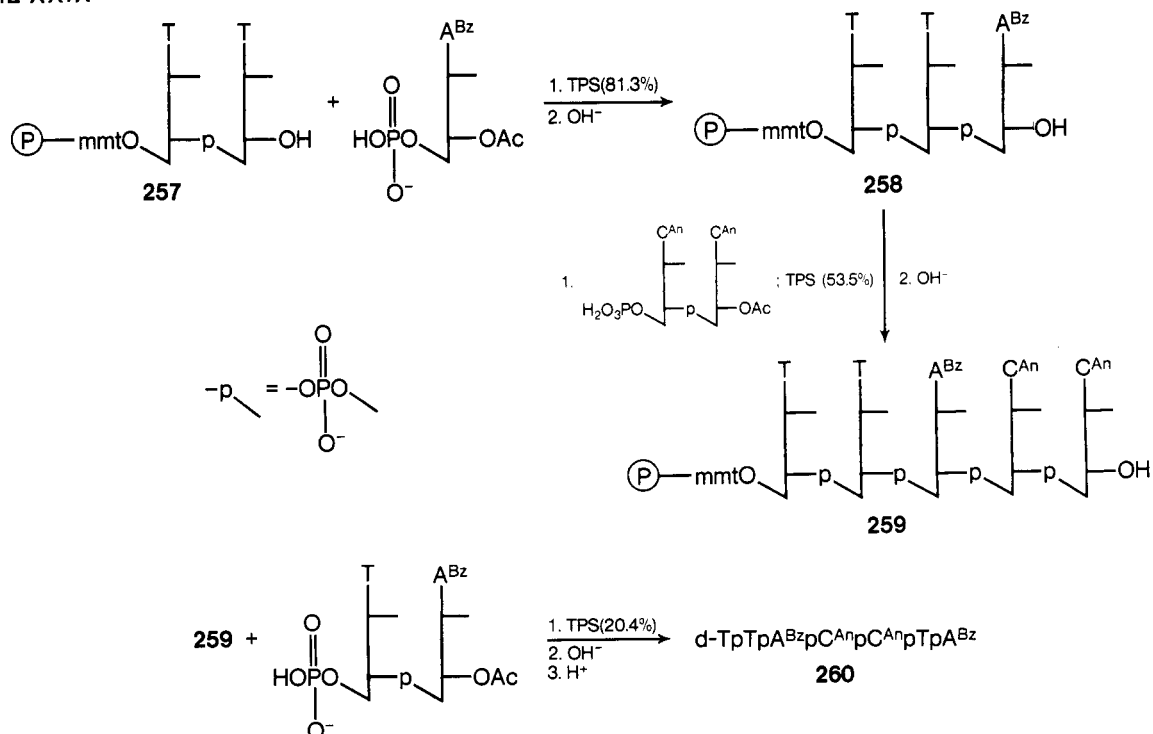

two deserve particular mention. One⁵⁵² describes the total synthesis of the bihelical DNA corresponding to the precursor for the *E. coli* tyrosine suppressor *t*-RNA. The other,⁵⁵⁷ which describes an RNA ligase for joining oligoribonucleotides, can be expected to have a profound effect on the synthesis of specific polyribonucleotides. The other papers generally extend the principles documented in the review, as summarized below: III.B.2,⁵¹⁶ III.B.2.b,⁵¹⁷ III.B.2.c,⁵¹⁸ III.B.2.d,^{519,520} IV.A,⁵²¹⁻⁵²⁵ IV.B,⁵²⁶⁻⁵³¹ V.A,⁵³² V.B.1,^{533,534} V.B.2,⁵³⁵ V.B.3,^{536,537} V.B.5,⁵³⁸⁻⁵⁴⁰ V.C.1,⁵⁴¹ V.C.2.a,⁵⁴²⁻⁵⁴⁶ V.C.2.b,⁵⁴⁷⁻⁵⁵⁰ V.D.1,⁵⁵¹ V.D.2,⁵⁵²⁻⁵⁶⁰ V.E,⁵⁶¹⁻⁵⁶³ and V1.^{564,565}

Acknowledgments. The authors appreciate the partial support of this effort by a grant, CA 11935, from the National Cancer Institute. The able assistance of Mrs. Linda F. Anderson in preparing the manuscript is also gratefully acknowledged.

VIII. References and Notes

- H. G. Khorana in "The Harvey Lectures", Series 62, Academic Press, New York, N.Y., 1968, p 79.
- H. G. Khorana, H. Buchi, T. M. Jacob, H. Kossel, S. A. Narang, and E. Ohtsuka, *J. Am. Chem. Soc.*, **89**, 2154 (1967).
- P. C. Loewen, T. Sekiya, and H. G. Khorana, *J. Biol. Chem.*, **249**, 217 (1974).
- C. L. Harvey, R. Wright, A. F. Cook, D. T. Maichuk, and A. L. Nussbaum, *Biochemistry*, **12**, 208 (1973).
- H. G. Khorana, *Pure Appl. Chem.*, **71**, 349 (1968).
- S. M. Zhenodarova, *Russ. Chem. Rev.*, **34**, 21 (1965).
- F. Cramer, *Angew. Chem., Int. Ed. Engl.*, **5**, 173 (1966).
- S. M. Zhenodarova and M. I. Habarova, *Russ. Chem. Rev.*, **35**, 531 (1966).
- K. L. Agarwal, H. Buchi, M. H. Caruthers, N. Gupta, H. G. Khorana, E. Kleppe, A. Kumar, E. Ohtsuka, U. L. Rajbhandari, J. H. van de Sande, V. Sgarameilla, H. Weber, and T. Yamada, *Nature (London)*, **227**, 27 (1970).
- H. G. Khorana, K. L. Agarwal, H. Buchi, M. H. Caruthers, N. Gupta, E. Kleppe, A. Kumar, E. Ohtsuka, U. L. Rajbhandari, J. H. van de Sande, V. Sgarameilla, T. Terao, H. Weber, and Y. Yamada, *J. Mol. Biol.*, **72**, 209 (1972).
- T. Neilson and E. S. Werstiuk, *J. Am. Chem. Soc.*, **96**, 2295 (1974).
- K. L. Agarwal, A. Yamazaki, P. J. Cashion, and H. G. Khorana, *Angew. Chem., Int. Ed. Engl.*, **11**, 451 (1972).
- M. Ikehara, *Acc. Chem. Res.*, **7**, 92 (1974).
- In addition to the abbreviations recommended by IUPAC-IUB commission,¹⁵ the following were also used: An, anisoyl; B, purine or pyrimidine base; iBu, isobutryl; ce, cyanoethyl; DCC, *N,N*-dicyclohexylcarbodiimide; dcm, dihydrocoumariloyl; dhc, dihydrocinnamoyl; dmm, *N*-dimethylaminomethylene; ibc, isobutyloxycarbonyl; MS, mesitylenesulfonyl chloride; N, nucleoside; ⊖-, polymer residue; pda, *o*-phenylenedioxyacetyl; Pv, pivalyl; TEAB, triethylammonium hydrogen carbonate; TPS, 2,4,6-triisopropylbenzenesulfonyl chloride.
- J. Mol. Biol.*, **55**, 299 (1971); or *Biochemistry*, **9**, 4022 (1970).
- A. Holy, *Collect. Czech. Chem. Commun.*, **35**, 3686 (1970).
- A. F. Cook and J. G. Moffatt, *J. Am. Chem. Soc.*, **89**, 2697 (1967).
- R. H. Hall and R. Thedford, *J. Org. Chem.*, **28**, 1506 (1963).
- M. Smith and H. G. Khorana, *J. Am. Chem. Soc.*, **81**, 2911 (1959).
- M. Smith, D. H. Rammier, I. H. Goldberg, and H. G. Khorana, *J. Am. Chem. Soc.*, **84**, 430 (1962).
- D. B. Straus and J. R. Fresno, *J. Am. Chem. Soc.*, **87**, 1364 (1965).
- B. E. Griffin, M. Jarman, and C. B. Reese, *Tetrahedron*, **24**, 639 (1968).
- T. Neilson and E. S. Werstiuk, *Can. J. Chem.*, **49**, 493 (1971).
- T. Neilson, E. V. Wastrowski, and E. S. Werstiuk, *Can. J. Chem.*, **51**, 1068 (1973).
- F. Eckstein and F. Cramer, *Chem. Ber.*, **98**, 995 (1965).
- J. Zemlicka and S. Chladek, *Tetrahedron Lett.*, 3057 (1965).
- J. Smrt and F. Sorm, *Collect. Czech. Chem. Commun.*, **27**, 73 (1962).
- C. B. Reese, R. Saffhill, and J. E. Sulston, *J. Am. Chem. Soc.*, **89**, 3366 (1967).
- C. B. Reese, R. Saffhill, and J. E. Sulston, *Tetrahedron*, **26**, 1023 (1970).
- J. H. van Boom, G. R. Owen, J. Preston, T. Ravindranathan, and C. B. Reese, *J. Chem. Soc. C*, 3230 (1971).
- J. H. van Boom, P. M. J. Burgers, G. R. Owen, C. B. Reese, and R. Saffhill, *J. Chem. Soc., Chem. Commun.*, 869 (1971).
- J. H. van Boom, P. van Deursen, J. Meeuwse, and C. B. Reese, *J. Chem. Soc., Chem. Commun.*, 766 (1972).
- S. Chladek and J. Smrt, *Chem. Ind. (London)*, 1719 (1964).
- S. Chladek, J. Zemlicka, and F. Sorm, *Collect. Czech. Chem. Commun.*, **31**, 1785 (1966).
- J. Smrt, *Tetrahedron Lett.*, 3133 (1967).
- I. Tazawa, S. Tazawa, J. L. Alderfer, and P. O. P. Ts'o, *Biochemistry*, **11**, 4931 (1972).
- G. A. R. Johnston, *Tetrahedron*, **24**, 6987 (1968).
- D. H. Rammier and H. G. Khorana, *J. Am. Chem. Soc.*, **84**, 3112 (1962).
- C. B. Reese and D. R. Trentham, *Tetrahedron Lett.*, 2467 (1965).
- D. P. L. Green and C. B. Reese, *J. Chem. Soc., Chem. Commun.*, 729 (1968).
- H. P. M. Fromageot, C. B. Reese, and J. E. Sulston, *Tetrahedron*, **24**, 3533 (1968).
- C. Altona and M. Sundaralingam, *J. Am. Chem. Soc.*, **95**, 2333 (1973).
- H. P. M. Fromageot, B. E. Griffin, C. B. Reese, and J. E. Sulston, *Tetrahedron*, **23**, 2315 (1967).
- E. Ohtsuka, M. Ubasawa, and M. Ikehara, *J. Am. Chem. Soc.*, **93**, 2296 (1971).
- F. Cramer, H. P. Bar, H. J. Rhaese, W. Sanger, K. H. Scheit, G. Schneider, and J. Tennigkeit, *Tetrahedron Lett.*, 1039 (1963).
- J. Zemlicka, J. Beranek, and J. Smrt, *Collect. Czech. Chem. Commun.*, **27**, 2784 (1962).
- A. Holy, *Collect. Czech. Chem. Commun.*, **35**, 3584 (1970).
- E. A. Sedelnikova and S. M. Zhenodarova, *Zh. Obshch. Khim.*, **38**, 2234 (1968).
- E. A. Sedelnikova and S. M. Zhenodarova, *Zh. Obshch. Khim.*, **39**, 2268 (1969).
- S. M. Zhenodarova and E. A. Sedelnikova, *Biochim. Biophys. Acta*, **195**, 8 (1969).
- E. A. Sedelnikova, V. P. Kljagina, and S. M. Zhenodarova, *Mol. Biol. (Moscow)*, **7**, 27 (1973).
- J. Smrt and S. Chladek, *Collect. Czech. Chem. Commun.*, **31**, 2978 (1966).
- F. Cramer, H. J. Rhaese, S. Rittner, and K. H. Scheit, *Justus Liebig's Ann. Chem.*, **683**, 199 (1965).
- F. Cramer, K. H. Scheit, and H. J. Rhaese, *Justus Liebig's Ann. Chem.*, **693**, 244 (1966).
- E. Ohtsuka, H. Tagawa, and M. Ikehara, *Chem. Pharm. Bull.*, **19**, 139 (1971).
- H. Schaller, G. Weimann, B. Lerch, and H. G. Khorana, *J. Am. Chem. Soc.*, **85**, 3821 (1963).
- C. B. Reese and D. R. Trentham, *Tetrahedron Lett.*, 2459 (1965).
- B. E. Griffin, C. B. Reese, G. F. Stevenson, and D. R. Trentham, *Tetrahedron Lett.*, 4349 (1966).
- K. Kikugawa, F. Sato, T. Tsurao, N. Imura, and T. Ukita, *Chem. Pharm. Bull.*, **16**, 1110 (1968).
- H. U. Blank, D. Frahne, A. Myles, and W. Pfeleiderer, *Justus Liebig's Ann. Chem.*, **742**, 34 (1970).
- H. U. Blank and W. Pfeleiderer, *Justus Liebig's Ann. Chem.*, **742**, 1, 16 (1970).
- W. Hutzenlaub and W. Pfeleiderer, *Chem. Ber.*, **106**, 665 (1973).
- L. F. Christensen and A. D. Broom, *J. Org. Chem.*, **37**, 3498 (1972).
- J. Baker, M. Jarman, and J. A. Stock, *Biochem. Pharmacol.*, **22**, 2208 (1973).
- J. A. Barltrop, P. J. Plant, and P. Schofield, *Chem. Commun.*, 822 (1966).
- A. Pachornik, B. Amit, and R. B. Woodward, *J. Am. Chem. Soc.*, **92**, 6333 (1970).
- U. Zehavi, B. Amit, and A. Pachornik, *J. Org. Chem.*, **37**, 2281 (1972).
- U. Zehavi and A. Pachornik, *J. Org. Chem.*, **37**, 2285 (1972); *J. Am. Chem. Soc.*, **95**, 5673 (1973).
- D. G. Bartholomew, Thesis, University of Utah, Salt Lake City, Utah, 1974.
- D. G. Bartholomew and A. D. Broom, Abstracts, 167th National Meeting of the American Chemical Society, Los Angeles, Calif., March 1974, No. MEDI-66; *J. Chem. Soc., Chem. Commun.*, 38 (1975).
- E. Ohtsuka, S. Tanaka, and M. Ikehara, *Nucleic Acid Res.*, **1**, 1351 (1974).
- D. Wagner, J. P. H. Verheyden, and J. G. Moffatt, *J. Org. Chem.*, **39**, 24 (1974).
- Y. Mizuno, T. Endo, and T. Nakamura, *J. Org. Chem.*, **40**, 1391 (1975).
- Y. Mizuno, T. Endo, and K. Ikeda, *J. Org. Chem.*, **40**, 1385 (1975).
- N. C. Yung and J. J. Fox, *J. Am. Chem. Soc.*, **83**, 3060 (1961).
- J. Zemlicka, *Collect. Czech. Chem. Commun.*, **29**, 1734 (1964).
- H. U. Blank and W. Pfeleiderer, *Tetrahedron Lett.*, 869 (1967).
- R. Lohrmann and H. G. Khorana, *J. Am. Chem. Soc.*, **86**, 4188 (1964).
- Y. Lapidot and H. G. Khorana, *J. Am. Chem. Soc.*, **85**, 3852 (1963).
- D. H. Rammier, Y. Lapidot, and H. G. Khorana, *J. Am. Chem. Soc.*, **85**, 1989 (1963).
- E. Ohtsuka and H. G. Khorana, *J. Am. Chem. Soc.*, **89**, 2195 (1967).
- G. L. Greene and R. L. Letsinger, *Tetrahedron Lett.*, 2081 (1975).
- A. Taunton-Rigby, Y. H. Kim, C. J. Crassup, and N. A. Starkovsky, *J. Org. Chem.*, **37**, 956 (1972).
- T. Neilson and E. S. Werstiuk, *Can. J. Chem.*, **49**, 3004 (1971).
- P. J. Cashion, M. Fridkin, K. L. Agarwal, E. Jay, and H. G. Khorana, *Biochemistry*, **12**, 1985 (1973).
- G. W. Grams and R. L. Letsinger, *J. Org. Chem.*, **35**, 868 (1970).
- A. Hampton, *J. Am. Chem. Soc.*, **87**, 4654 (1965).
- D. P. L. Green, T. Ravindranathan, C. B. Reese, and R. Saffhill, *Tetrahedron*, **23**, 1031 (1970).
- J. Smrt and H. Holy, *Tetrahedron Lett.*, 981 (1967).
- E. A. Sedelnikova and S. M. Zhenodarova, *Zh. Obshch. Khim.*, **38**, 415 (1968).
- R. Brimacombe, W. Kemper, T. Yaonini, and J. Smrt, *Collect. Czech. Chem. Commun.*, **33**, 2074 (1968).
- M. Saneyoshi, *Chem. Pharm. Bull.*, **16**, 1400 (1968).
- R. J. Cedergren, B. Larue, and P. Laporte, *Can. J. Biochem.*, **49**, 730 (1971).
- A. Holy and M. Soucek, *Tetrahedron Lett.*, 185 (1971).
- O. Mitsunobu, J. Kimura, and Y. Fujisawa, *Bull. Chem. Soc. Jpn.*, **45**, 245 (1972).
- E. S. Werstiuk and T. Neilson, *Can. J. Chem.*, **50**, 1283 (1972).
- E. S. Werstiuk and T. Neilson, *Can. J. Chem.*, **51**, 1889 (1973).
- N. I. Grineva, V. F. Zrytova, and D. G. Knorre, *Izv. Sib. Otd. Akad. Nauk SSSR, Ser. Khim. Nauk*, **5**, 118 (1968); *Chem. Abstr.*, **70**, 115473u (1969).

- (100) S. Chladek and J. Smrt, *Collect. Czech. Chem. Commun.*, **29**, 219 (1964).
- (101) H. Seliger, H. Schutz, E. Saur, and M. Philipp, *J. Carbohydr. Nucleosides Nucleotides*, **2**, 79 (1975).
- (102) A. Holy and J. Smrt, *Collect. Czech. Chem. Commun.*, **31**, 3800 (1966).
- (103) B. E. Griffin and C. B. Reese, *Tetrahedron Lett.*, 2925 (1964).
- (104) R. L. Letsinger and K. K. Ogilvie, *J. Org. Chem.*, **32**, 296 (1967).
- (105) G. Kressze, E. Lodemann, and A. Wacker, *Z. Naturforsch. B*, **22**, 285 (1967).
- (106) C. B. Reese and J. C. M. Stewart, *Tetrahedron Lett.*, 4273 (1968).
- (107) W. T. Markiewicz and M. Wiewirowski, *Nucleic Acid Res.*, **2**, 951 (1975).
- (108) K. F. Yip and K. C. Tsou, *J. Am. Chem. Soc.*, **93**, 3272 (1971).
- (109) A. F. Cook and D. T. Maichuk, *J. Org. Chem.*, **35**, 1940 (1970).
- (110) M. Masaki, T. Kitahara, H. Kurita, and M. Ohta, *J. Am. Chem. Soc.*, **90**, 4508 (1968).
- (111) R. L. Letsinger, J. Fontaine, V. Mahadevan, D. A. Schexnayder, and R. E. Leone, *J. Org. Chem.*, **29**, 2615 (1964).
- (112) G. W. Grams and R. L. Letsinger, *J. Org. Chem.*, **33**, 2589 (1968).
- (113) F. Eckstein, *Tetrahedron Lett.*, 531 (1965).
- (114) R. L. Letsinger, M. H. Caruthers, P. S. Miller, K. K. Ogilvie, *J. Am. Chem. Soc.*, **89**, 7146 (1967).
- (115) R. L. Letsinger and P. S. Miller, *J. Am. Chem. Soc.*, **91**, 3356 (1969).
- (116) R. L. Letsinger, K. K. Ogilvie, and P. S. Miller, *J. Am. Chem. Soc.*, **91**, 3360 (1969).
- (117) A. F. Cook, *J. Org. Chem.*, **33**, 3589 (1968).
- (118) Y. Sasaki and T. Hashizume, *Anal. Biochem.*, **16**, 1 (1966).
- (119) T. Hashizume and Y. Sasaki, *Anal. Biochem.*, **15**, 199 (1966).
- (120) E. J. Corey and A. Venkateswarlu, *J. Am. Chem. Soc.*, **94**, 6190 (1972).
- (121) K. K. Ogilvie and D. J. Iwacha, *Tetrahedron Lett.*, 317 (1973).
- (122) K. K. Ogilvie, *Can. J. Chem.*, **51**, 3799 (1973).
- (123) J. McCloskey, A. M. Lawson, K. Tsuboyama, P. M. Krueger, and R. N. Stillwell, *J. Am. Chem. Soc.*, **90**, 4182 (1968).
- (124) K. K. Ogilvie, E. A. Thompson, M. A. Quilliam, and J. B. Westmore, *Tetrahedron Lett.*, 2865 (1974).
- (125) K. K. Ogilvie, K. L. Sadana, E. A. Thompson, M. A. Quilliam, and L. B. Westmore, *Tetrahedron Lett.*, 2861 (1974).
- (126) A. Hassner, G. Strand, M. Rubinstein, and A. Pachornik, *J. Am. Chem. Soc.*, **97**, 1614 (1975).
- (127) H. S. Sachdev and N. A. Starkovsky, *Tetrahedron Lett.*, 733 (1969).
- (128) A. Taunton-Rigby, *J. Org. Chem.*, **38**, 977 (1973).
- (129) K. L. Agarwal and H. G. Khorana, *J. Am. Chem. Soc.*, **94**, 3578 (1972).
- (130) P. A. Levene and R. S. Tipson, *J. Biol. Chem.*, **106**, 113 (1934); **121**, 131 (1937).
- (131) R. W. Chambers, J. G. Moffatt, and H. G. Khorana, *J. Am. Chem. Soc.*, **79**, 3747 (1957).
- (132) R. W. Chambers, R. Shapiro, and V. Kurkov, *J. Am. Chem. Soc.*, **82**, 970 (1960).
- (133) A. Hampton, *J. Am. Chem. Soc.*, **83**, 3640 (1961).
- (134) S. Chladek and J. Smrt, *Collect. Czech. Chem. Commun.*, **28**, 1301 (1963).
- (135) A. Hampton, J. C. Fratantoni, and P. M. Carroll, *J. Am. Chem. Soc.*, **87**, 5481 (1965).
- (136) F. Cramer, W. Sanger, K. H. Scheit, and J. Tennigkeit, *Justus Liebig's Ann. Chem.*, **679**, 156 (1964).
- (137) N. Bagget, A. B. Foster, J. M. Webber, D. Lipkin, and B. E. Phillips, *Chem. Ind. (London)*, 136 (1965).
- (138) I. Tazawa, S. Tazawa, L. M. Stempel, and P. O. P. Ts'o, *Biochemistry*, **9**, 3499 (1970).
- (139) F. Kathawala and F. Cramer, *Justus Liebig's Ann. Chem.*, **709**, 185 (1967).
- (140) C. B. Reese and J. E. Sulston, *Proc. Chem. Soc., London*, 214 (1964).
- (141) J. A. Montgomery and H. J. Thomas, *J. Am. Chem. Soc.*, **87**, 5442 (1965).
- (142) A. Hampton and A. W. Nichol, *J. Org. Chem.*, **32**, 1688 (1967).
- (143) A. Hampton and A. W. Nichol, *Biochemistry*, **5**, 2076 (1966).
- (144) G. R. Niaz and C. B. Reese, *J. Chem. Soc., Chem. Commun.*, 552 (1969).
- (145) J. H. van Boom, J. F. M. de Rooy, and C. B. Reese, *J. Chem. Soc., Perkin Trans. 1*, 2513 (1973), and references cited in it.
- (146) D. Soll and H. G. Khorana, *Angew. Chem., Int. Ed. Engl.*, **3**, 374 (1964).
- (147) D. Soll and H. G. Khorana, *J. Am. Chem. Soc.*, **87**, 350 (1965).
- (148) J. Smrt and F. Sorm, *Collect. Czech. Chem. Commun.*, **28**, 2415 (1963).
- (149) H. J. Rhaese, W. Siehr, and F. Cramer, *Justus Liebig's Ann. Chem.*, **703**, 215 (1967).
- (150) E. Ohtsuka, M. Ubasawa, and M. Ikehara, *J. Am. Chem. Soc.*, **92**, 3445 (1970).
- (151) M. Ikehara and E. Ohtsuka, *Chem. Pharm. Bull.*, **12**, 145 (1964).
- (152) A. M. Yurkevich, I. I. Kolodkina, and N. A. Preobrazhenskii, *Dokl. Akad. Nauk SSSR*, **164**, 828 (1965).
- (153) A. M. Yurkevich, L. S. Varshavskaya, I. I. Kolodkina, and N. A. Preobrazhenskii, *Zh. Obshch. Khim.*, **37**, 2002 (1967).
- (154) I. I. Kolodkina, L. S. Varshavskaya, A. M. Yurkevich, and N. A. Preobrazhenskii, *Zh. Obshch. Khim.*, **37**, 1996 (1967).
- (155) R. B. Woodward, K. Heusler, J. Gesteli, P. Naegeli, W. Oepelzer, R. Ramage, S. Ranganathan, and H. Vorbruggen, *J. Am. Chem. Soc.*, **88**, 852 (1966).
- (156) F. Eckstein, *Angew. Chem., Int. Ed. Engl.*, **5**, 671 (1966).
- (157) F. Eckstein and I. Rizk, *Angew. Chem., Int. Ed. Engl.*, **6**, 695 (1967).
- (158) F. Eckstein, *Chem. Ber.*, **100**, 2236 (1967).
- (159) F. Eckstein and I. Rizk, *Chem. Ber.*, **102**, 2362 (1969).
- (160) G. Weimann and H. G. Khorana, *J. Am. Chem. Soc.*, **84**, 419, 4329 (1962).
- (161) H. Schaller and H. G. Khorana, *J. Am. Chem. Soc.*, **85**, 3828 (1963).
- (162) G. Weimann, H. Schaller, and H. G. Khorana, *J. Am. Chem. Soc.*, **85**, 3835 (1963).
- (163) R. L. Letsinger and K. K. Ogilvie, *J. Am. Chem. Soc.*, **89**, 4801 (1967); **91**, 3350 (1969).
- (164) C. B. Reese and R. Saffhill, *J. Chem. Soc., Chem. Commun.*, 767 (1968).
- (165) N. J. Cusack, C. B. Reese, and J. H. van Boom, *Tetrahedron Lett.*, 2209 (1973).
- (166) K. Itakura, C. P. Bahl, N. Katagiri, J. J. Michniewicz, R. H. Wightman, and S. A. Narang, *Can. J. Chem.*, **51**, 3649 (1973).
- (167) J. H. van Boom, P. M. J. Burgers, P. H. van Deursen, R. Arentzen, and C. B. Reese, *Tetrahedron Lett.*, 3785 (1974).
- (168) T. Hata and M. Sekine, *Chem. Lett.*, 837 (1974).
- (169) M. Sekine and T. Hata, *Tetrahedron Lett.*, 1711 (1975).
- (170) T. Hata and M. Sekine, *J. Am. Chem. Soc.*, **96**, 7363 (1974).
- (171) A. Franke, F. Eckstein, K. H. Scheit, and F. Cramer, *Chem. Ber.*, **101**, 944 (1968).
- (172) A. L. Nussbaum and R. Tiberi, *J. Am. Chem. Soc.*, **87**, 2513 (1965).
- (173) A. F. Cook, *J. Am. Chem. Soc.*, **92**, 190 (1970).
- (174) A. F. Cook, M. J. Holman, and A. L. Nussbaum, *J. Am. Chem. Soc.*, **91**, 1522 (1969).
- (175) A. F. Cook, M. J. Holman, and A. L. Nussbaum, *J. Am. Chem. Soc.*, **91**, 6479 (1969).
- (176) A. F. Cook, E. P. Heimer, M. J. Holman, D. T. Maichuk, and A. L. Nussbaum, *J. Am. Chem. Soc.*, **94**, 1334 (1972).
- (177) E. Helmer, M. Ahmad, S. Roy, A. Ramel, and A. L. Nussbaum, *J. Am. Chem. Soc.*, **94**, 1707 (1972).
- (178) M. S. Poonian, E. F. Nowoswiat, and A. L. Nussbaum, *J. Am. Chem. Soc.*, **94**, 3992 (1972).
- (179) R. H. Wightman, S. A. Narang, and K. Itakura, *Can. J. Chem.*, **50**, 456 (1972).
- (180) S. A. Narang, O. S. Bhanot, J. Goodchild, R. H. Wightman, and S. K. Dheer, *J. Am. Chem. Soc.*, **94**, 6183 (1972).
- (181) K. L. Agarwal, M. Fridkin, E. Jay, and H. G. Khorana, *J. Am. Chem. Soc.*, **95**, 2020 (1973).
- (182) E. Ohtsuka, S. Morioka, and M. Ikehara, *J. Am. Chem. Soc.*, **95**, 8348 (1973).
- (183) F. Cramer and K. H. Scheit, *Justus Liebig's Ann. Chem.*, **679**, 150 (1964).
- (184) W. Freist, R. Helbig, and F. Cramer, *Chem. Ber.*, **103**, 1032 (1970).
- (185) N. Katagiri, C. P. Bahl, K. Itakura, J. Michniewicz, and S. A. Narang, *J. Chem. Soc., Chem. Commun.*, 803 (1973).
- (186) R. K. Borden and M. Smith, *J. Org. Chem.*, **31**, 3241 (1966).
- (187) P. W. Johnson and M. Smith, *J. Chem. Soc., Chem. Commun.*, 379 (1971).
- (188) A. J. Kirby and A. G. Varboglis, *J. Chem. Soc. B*, 135 (1968).
- (189) S. A. Narang, O. S. Bhanot, J. Goodchild, and R. H. Wightman, *J. Chem. Soc., Chem. Commun.*, 91 (1970).
- (190) S. A. Narang, O. S. Bhanot, J. Goodchild, J. Michniewicz, R. H. Wightman, and S. K. Dheer, *J. Chem. Soc., Chem. Commun.*, 516 (1970).
- (191) Y. Mizuno, T. Endo, T. Miyaoka, and K. Ikeda, *J. Org. Chem.*, **39**, 1250 (1974).
- (192) M. Rubinstein, B. Amit, and A. Patchornik, *Tetrahedron Lett.*, 1445 (1975).
- (193) E. Ohtsuka, K. Murao, M. Ubasawa, and M. Ikehara, *J. Am. Chem. Soc.*, **92**, 3441 (1970).
- (194) J. G. Moffatt and H. G. Khorana, *J. Am. Chem. Soc.*, **83**, 649 (1961).
- (195) Yu. A. Berlin, M. N. Kolosov, V. G. Korobko, and O. G. Chakhmakheva, *Khim. Prir. Soedin.*, **9**, 410 (1973); *Chem. Abstr.*, **79**, 66726d (1973).
- (196) E. Ohtsuka, A. Honda, H. Shigyo, S. Morioka, T. Sugiyama, and M. Ikehara, *Nucleic Acid Res.*, **1**, 223 (1974).
- (197) A. G. Badashkaya, V. F. Zarytova, D. G. Knorre, and T. N. Shubina, *Bioorg. Khim.*, **1**, 293 (1975).
- (198) K. L. Agarwal, A. Yamazaki, and H. G. Khorana, *J. Am. Chem. Soc.*, **93**, 2754 (1971).
- (199) T. Hata, K. Tajima, and T. Mukaiyama, *J. Am. Chem. Soc.*, **93**, 4928 (1971).
- (200) K. Tajima and T. Hata, *Bull. Chem. Soc. Jpn.*, **45**, 2608 (1971).
- (201) T. Hata, I. Nakagawa, and N. Takebayashi, *Tetrahedron Lett.*, 2931 (1972).
- (202) T. Hata, I. Nakagawa, and Y. Nakada, *Tetrahedron Lett.*, 467 (1975).
- (203) P. T. Gilham and H. G. Khorana, *J. Am. Chem. Soc.*, **81**, 4647 (1959).
- (204) G. M. Tener, *J. Am. Chem. Soc.*, **83**, 159 (1961).
- (205) S. A. Narang, K. Itakura, and R. H. Wightman, *Can. J. Chem.*, **50**, 769 (1972).
- (206) J. Smrt, *Collect. Czech. Chem. Commun.*, **38**, 3932 (1973).
- (207) H. G. Khorana, A. F. Turner, and J. P. Vizsolyi, *J. Am. Chem. Soc.*, **83**, 686 (1961).
- (208) J. Zemlicka, *Collect. Czech. Chem. Commun.*, **28**, 1060 (1963).
- (209) J. Zemlicka, S. Chladek, A. Holy, and J. Smrt, *Collect. Czech. Chem. Commun.*, **31**, 3198 (1966).
- (210) J. Zemlicka and A. Holy, *Collect. Czech. Chem. Commun.*, **32**, 3159 (1967).
- (211) A. Holy, S. Chladek, and J. Zemlicka, *Collect. Czech. Chem. Commun.*, **34**, 253 (1969).
- (212) J. Smrt, *Collect. Czech. Chem. Commun.*, **37**, 4088 (1972).
- (213) D. L. MacDonald and H. G. Fletcher, *J. Am. Chem. Soc.*, **81**, 3719 (1959).
- (214) A. M. Michelson, *J. Chem. Soc.*, 3655 (1959).
- (215) K. K. Raip and H. G. Khorana, *J. Am. Chem. Soc.*, **83**, 2926 (1961).
- (216) H. Buchi and H. G. Khorana, *J. Mol. Biol.*, **72**, 251 (1972).
- (217) H. Weber and H. G. Khorana, *J. Mol. Biol.*, **72**, 219 (1972).
- (218) K. A. Watanabe and J. J. Fox, *Angew. Chem., Int. Ed. Engl.*, **5**, 579 (1966).

- (219) T. M. Jacob and H. G. Khorana, *J. Am. Chem. Soc.*, **86**, 1630 (1964).
(220) R. Lohrman and H. G. Khorana, *J. Am. Chem. Soc.*, **88**, 829 (1966).
(221) T. M. Jacob and H. G. Khorana, *Chem. Ind. (London)*, 932 (1962).
(222) F. Cramer, K. H. Scheit, G. Schneider, and J. Tennigkeit, *Angew. Chem., Int. Ed. Engl.*, **1**, 331 (1962).
(223) F. Cramer, H. J. Baldauf, and H. Kuntzel, *Angew. Chem., Int. Ed. Engl.*, **1**, 54 (1962).
(224) F. Cramer, R. Wittmann, K. Daneck, and G. Weimann, *Angew. Chem., Int. Ed. Engl.*, **2**, 43 (1963).
(225) M. W. Moon and H. G. Khorana, *J. Am. Chem. Soc.*, **88**, 1805 (1966).
(226) G. M. Blackburn, M. J. Brown, M. R. Harris, and D. Shire, *J. Chem. Soc. C*, 676 (1969).
(227) V. F. Zarytova et al., *Dokl. Akad. Nauk SSSR*, **212**, 630 (1973).
(228) D. G. Knorre, A. V. Lebedev, A. S. Levina, A. I. Rezvukhin, and V. F. Zarytova, *Tetrahedron*, **30**, 3073 (1974).
(229) R. Weiss and E. Birch-Hirschfeld, *J. Prakt. Chem.*, **317**, 525 (1975).
(230) Yu. Berlin, O. G. Chakhmakheva, V. A. Efimov, M. N. Kolosov, and V. G. Korobko, *Tetrahedron Lett.*, 1353 (1973).
(231) N. Katagiri, K. Itakura, and S. A. Narang, *J. Chem. Soc., Chem. Commun.*, 325 (1974).
(232) K. Itakura, N. Katagiri, and S. A. Narang, *Can. J. Chem.*, **52**, 3689 (1974).
(233) M. Rubinstein and M. Patchornik, *Tetrahedron Lett.*, 2881 (1972).
(234) T. Mukaiyama, R. Matsueda, and M. Suzuki, *Tetrahedron Lett.*, 1901 (1970).
(235) T. Mukaiyama and M. Hashimoto, *Bull. Chem. Soc. Jpn.*, **44**, 196 (1971).
(236) T. Mukaiyama and M. Hashimoto, *Bull. Chem. Soc. Jpn.*, **44**, 2284 (1971).
(237) J. C. Sheehan and J. J. Hlavka, *J. Org. Chem.*, **21**, 439 (1956).
(238) M. Smith and H. G. Khorana, *J. Am. Chem. Soc.*, **80**, 1141 (1958).
(239) R. Naylor and P. T. Gilham, *Biochemistry*, **5**, 2722 (1966).
(240) J. Sulston, R. Lohrmann, L. E. Orgel, and H. T. Miles, *Proc. Natl. Acad. Sci. U.S.A.*, **59**, 726 (1968).
(241) P. C. Srivastava, K. L. Nagpal, and M. M. Dhar, *Experientia*, **25**, 356 (1969).
(242) R. von Tigerstorn and M. Smith, *Science*, **167**, 1267 (1970).
(243) E. Ohtsuka, S. Morioka, and M. Ikehara, *Tetrahedron Lett.*, 2553 (1972).
(244) M. M. Kabachnik, V. K. Potapov, A. A. Shabarova, and M. A. Prokof'ev, *Dokl. Akad. Nauk SSSR*, **201**, 858 (1971).
(245) R. L. Letsinger, J. L. Finnan, G. A. Heavner, and W. B. Lunsford, *J. Am. Chem. Soc.*, **97**, 3278 (1975).
(246) Y. Mizuno and T. Sasaki, *J. Am. Chem. Soc.*, **88**, 863 (1966).
(247) J. Zemlicka and J. Smrt, *Tetrahedron Lett.*, 2081 (1964).
(248) J. Nagyvary and J. S. Roth, *Tetrahedron Lett.*, 614 (1965).
(249) J. Nagyvary, *Biochemistry*, **5**, 1316 (1966).
(250) K. L. Agarwal and M. M. Dhar, *Tetrahedron Lett.*, 2541 (1965).
(251) Y. Mizuno, T. Sasaki, T. Kanai, and H. Igarashi, *J. Org. Chem.*, **30**, 1533 (1965).
(252) Y. Mizuno and T. Sasaki, *Tetrahedron Lett.*, 4579 (1965).
(253) P. C. Srivastava, M. M. Dhar, and K. L. Nagpal, *Indian J. Chem.*, **7**, 1055 (1969).
(254) K. L. Nagpal and M. M. Dhar, *Tetrahedron Lett.*, 47 (1968).
(255) P. C. Srivastava, K. L. Nagpal, and M. M. Dhar, *Experientia*, **24**, 657 (1968).
(256) W. Jahn, *Chem. Ber.*, **98**, 1705 (1965).
(257) A. M. Michelson, *J. Chem. Soc.*, 1371 (1959).
(258) P. R. Taylor and R. H. Hall, *J. Org. Chem.*, **29**, 1078 (1964).
(259) J. L. Sussman, I. Barzilay, M. Keren-zur, and Y. Lapidot, *Biochim. Biophys. Acta*, **308**, 189 (1973).
(260) Y. Lapidot, I. Barzilay, and D. Salomon, *Anal. Biochem.*, **49**, 301 (1972).
(261) H. Nishimura, T. Sekiya, and T. Ukita, *Biochim. Biophys. Acta*, **174**, 653 (1969).
(262) H. Follmann, *Tetrahedron Lett.*, 2113 (1967).
(263) K. Miura and T. Ueda, *Chem. Pharm. Bull.*, **19**, 2567 (1971).
(264) C. Coutsogeorgopoulos and H. G. Khorana, *J. Am. Chem. Soc.*, **86**, 2926 (1964).
(265) H. G. Khorana and J. P. Vizsolyi, *J. Am. Chem. Soc.*, **83**, 675 (1961).
(266) R. K. Ralph, W. J. Conners, H. Schaller, and H. G. Khorana, *J. Am. Chem. Soc.*, **85**, 1983 (1963).
(267) Y. Lapidot and H. G. Khorana, *J. Am. Chem. Soc.*, **85**, 3857 (1963).
(268) W. Bahr, H. Sommer, and K. H. Scheit, *Biochim. Biophys. Acta*, **287**, 427 (1972).
(269) W. Falk and Ch. Tamm, *Helv. Chim. Acta*, **55**, 1928 (1972).
(270) D. B. Straus and J. R. Fresco, *J. Am. Chem. Soc.*, **95**, 5025 (1973).
(271) T. Kusama and H. Hayatsu, *Chem. Pharm. Bull.*, **18**, 319 (1970).
(272) H. Seliger and G. Aumann, *Tetrahedron Lett.*, 2911 (1973).
(273) M. Ikehara and S. Uesugi, *J. Am. Chem. Soc.*, **94**, 9189 (1972).
(274) J. Nagyvary and K. L. Nagpal, *Science*, **177**, 272 (1972).
(275) O. Pongs and P. O. P. Ts'o, *Biochem. Biophys. Res. Commun.*, **36**, 475 (1969).
(276) O. Pongs and P. O. P. Ts'o, *J. Am. Chem. Soc.*, **93**, 5241 (1971).
(277) G. Schramm, H. Grottsch, and W. Pollmann, *Angew. Chem., Int. Ed. Engl.*, **1**, 1 (1962).
(278) N. K. Kochetkov, E. I. Budowsky, V. D. Domkin, and M. N. Khromov-Borissov, *Biochim. Biophys. Acta*, **80**, 145 (1964).
(279) F. N. Hayes and E. Hansbury, *J. Am. Chem. Soc.*, **86**, 4172 (1964).
(280) H. Sawai and L. E. Orgel, *J. Am. Chem. Soc.*, **97**, 3532 (1975).
(281) E. Stephen-Sherwood, D. G. Odom, and J. Oro, *J. Mol. Evol.*, **3**, 323 (1974).
(282) E. Ohtsuka, R. W. Moon, and H. G. Khorana, *J. Am. Chem. Soc.*, **87**, 2956 (1965).
(283) H. G. Khorana, T. M. Jacob, M. W. Moon, S. A. Narang, and E. Ohtsuka, *J. Am. Chem. Soc.*, **87**, 2954 (1965).
(284) T. M. Jacob, S. A. Narang, and H. G. Khorana, *J. Am. Chem. Soc.*, **89**, 2177 (1967).
(285) S. A. Narang, T. M. Jacob, and H. G. Khorana, *J. Am. Chem. Soc.*, **89**, 2167 (1967).
(286) V. D. Smirnov, N. F. Sergeeva, E. V. Ilina, Z. A. Shabarova, and M. A. Prokof'ev, *Dokl. Akad. Nauk SSSR*, **218**, 722 (1974).
(287) F. Cramer, W. Folke, and H. Matzura, *Angew. Chem., Int. Ed. Engl.*, **6**, 562 (1967).
(288) J. Sulston, R. Lohrmann, L. E. Orgel, and H. T. Miles, *Proc. Natl. Acad. Sci. U.S.A.*, **60**, 409 (1968).
(289) J. Sulston, R. Lohrmann, L. E. Orgel, H. Schneider-Bernloehr, B. J. Weimann, and H. T. Miles, *J. Mol. Biol.*, **40**, 227 (1969).
(290) P. M. Pitha and J. Pitha, *Nature (London), New Biol.*, **240**, 78 (1972).
(291) S. Uesugi and P. O. P. Ts'o, *Biochemistry*, **13**, 3142 (1974).
(292) A. G. Badashkeeva, G. N. Kabasheva, D. G. Knorre, G. G. Shamovskii, and T. N. Shubina, *Dokl. Akad. Nauk SSSR*, **206**, 870 (1972).
(293) B. J. Weimann, R. Lohrmann, L. E. Orgel, H. Schneider-Bernloehr, and J. E. Sulston, *Science*, **161**, 387 (1968).
(294) V. K. Nedbal, N. I. Sokolova, Z. A. Shabarova, and M. A. Prokof'ev, *Dokl. Akad. Nauk SSSR*, **205**, 1114 (1972).
(295) Z. A. Shabarova and M. A. Prokof'ev, *FEBS Lett.*, **11**, 237 (1970).
(296) B. S. Zimmerman, J. W. Little, C. K. Oshinski, and H. Gellert, *Proc. Natl. Acad. Sci. U.S.A.*, **57**, 184 (1967).
(297) B. Weiss and L. C. Richardson, *Proc. Natl. Acad. Sci. U.S.A.*, **57**, 1021 (1967).
(298) N. K. Gupta, E. Ohtsuka, H. Weber, S. H. Chang, and H. G. Khorana, *Proc. Natl. Acad. Sci. U.S.A.*, **60**, 285 (1968).
(299) N. K. Gupta, E. Ohtsuka, V. Sgaramella, H. Buchi, A. Kumar, A. Weber, and H. G. Khorana, *Proc. Natl. Acad. Sci. U.S.A.*, **60**, 1338 (1968).
(300) V. Sgaramella and H. G. Khorana, *J. Mol. Biol.*, **72**, 493 (1972).
(301) A. Panet, J. H. van de Sande, P. C. Loewen, H. G. Khorana, A. J. Raae, J. R. Lillehaug, and K. Kleppe, *Biochemistry*, **12**, 5045 (1973).
(302) V. Sgaramella and H. G. Khorana, *J. Mol. Biol.*, **72**, 427 (1972).
(303) V. Sgaramella, K. Kleppe, T. Terao, N. K. Gupta, and H. G. Khorana, *J. Mol. Biol.*, **72**, 445 (1972).
(304) J. H. van de Sande, M. H. Caruthers, V. Sgaramella, T. Yamada, and H. G. Khorana, *J. Mol. Biol.*, **72**, 457 (1972).
(305) M. H. Caruthers, K. Kleppe, J. H. van de Sande, V. Sgaramella, K. L. Agarwal, H. Buchi, N. K. Gupta, A. Kumar, E. Ohtsuka, U. L. Rajbhandari, T. Terao, H. Weber, T. Yamada, and H. G. Khorana, *J. Mol. Biol.*, **72**, 475 (1972).
(306) A. J. Raae, J. R. Lillehaug, R. K. Kleppe, and K. Kleppe, *Nucleic Acid Res.*, **2**, 423 (1975).
(307) S. Gillam and M. Smith, *Nature (London), New Biol.*, **238**, 233 (1972).
(308) S. Gillam, K. Waterman, M. Doel, and M. Smith, *Nucleic Acid Res.*, **1**, 1649 (1974).
(309) S. Gillam and M. Smith, *Nucleic Acid Res.*, **1**, 1631 (1974).
(310) S. Gillam, K. Waterman, and M. Smith, *Nucleic Acid Res.*, **2**, 613 (1975).
(311) F. J. Bollum, E. Groeniger, and M. Yoneda, *Proc. Natl. Acad. Sci. U.S.A.*, **51**, 853 (1964).
(312) H. Kossel and R. Roychoudhury, *J. Biol. Chem.*, **249**, 4094 (1974).
(313) R. Roychoudhury, S. Kuhn, H. Schott, and H. Kossel, *FEBS Lett.*, **50**, 140 (1975).
(314) S. A. Narang, K. Itakura, and N. Katagiri, *Can. J. Biochem.*, **53**, 392 (1975).
(315) J. K. Mackey and P. T. Gilham, *Nature (London)*, **233**, 551 (1971).
(316) G. N. Bennett, J. K. Mackey, J. L. Wiebers, and P. T. Gilham, *Biochemistry*, **12**, 3956 (1973).
(317) G. Kaufmann, Z. Fridkin, A. Zutra, and U. Z. Littauer, *Eur. J. Biochem.*, **24**, 4 (1971).
(318) G. C. Walker and O. C. Uhlenbeck, *Biochemistry*, **14**, 817 (1975).
(319) Y. Kikuchi, K. Hirai, and K. Sakaguchi, *J. Biochem. (Tokyo)*, **77**, 469 (1975).
(320) J. J. Sninsky, G. N. Bennett, and P. T. Gilham, *Nucleic Acid Res.*, **1**, 1665 (1974).
(321) A. Holy, *Collect. Czech. Chem. Commun.*, **34**, 1261 (1969).
(322) A. Holy, D. Grunberger, and F. Sorm, *Biochim. Biophys. Acta*, **217**, 332 (1970).
(323) K. Sato-Asano and F. Egami, *Biochim. Biophys. Acta*, **29**, 655 (1958).
(324) K. Sato-Asano, *J. Biochem. (Tokyo)*, **48**, 284 (1960).
(325) K. Sato-Asano and F. Egami, *Nature (London)*, **185**, 462 (1960).
(326) K. Hayatsu and F. Egami, *J. Biochem. (Tokyo)*, **53**, 176 (1963).
(327) K. H. Scheit and F. Cramer, *Tetrahedron Lett.*, 2765 (1964).
(328) T. Sekiya, Y. Furuichi, M. Yoshida, and T. Ukita, *J. Biochem. (Tokyo)*, **63**, 514 (1968).
(329) J. Smrt, *Collect. Czech. Chem. Commun.*, **32**, 3380 (1967).
(330) S. C. Mohr and R. E. Thach, *J. Biol. Chem.*, **244**, 6566 (1969).
(331) D. Grunberger, A. Holy, and F. Sorm, *Collect. Czech. Chem. Commun.*, **33**, 286 (1968).
(332) M. J. Rowe and M. A. Smith, *Biochem. Biophys. Res. Commun.*, **38**, 393 (1970).
(333) M. J. Rowe and M. A. Smith, *Biochim. Biophys. Acta*, **247**, 187 (1971).
(334) T. Koike, T. Uchida, and F. Egami, *Biochim. Biophys. Acta*, **190**, 257 (1969).
(335) T. Koike, T. Uchida, and F. Egami, *J. Biochem. (Tokyo)*, **70**, 55 (1971).
(336) N. M. Abrosimova-Amel'yanichik, R. I. Tartarskaya, and A. A. Baev, *Mol. Biol. (Moscow)*, **1**, 307 (1967).
(337) L. P. Shershnova and T. V. Venkstern, *Mol. Biol. (Moscow)*, **5**, 480 (1971).
(338) R. Markham and J. D. Smith, *Biochem. J.*, **52**, 565 (1952).
(339) L. A. Heppel, P. R. Whitfield, and R. Markham, *Biochem. J.*, **60**, 8 (1955).
(340) G. E. Ustyuzhanin and E. M. Kogan, *Biokhimiya*, **35**, 708 (1970).
(341) A. P. Kavunenko, T. N. Kalacheva, and N. S. Tikhomirova-Sidorova, *Biokhimiya*, **39**, 839 (1974).

- (342) M. R. Bernfield and F. M. Rottman, *J. Biol. Chem.*, **242**, 4134 (1967).
- (343) N. S. Tikhomirova-Sidorova, G. E. Ustyuzhanin, and E. M. Kogan, *Biokhimiya*, **32**, 867 (1967).
- (344) S. M. Zhenodarova and M. I. Habarova, *Biochim. Biophys. Acta*, **169**, 559 (1968); **195**, 1 (1969).
- (345) M. Saito, Y. Furuichi, K. Takeishi, M. Yoshida, M. Yamasaki, K. Arimo, H. Hayatsu, and T. Ukita, *Biochim. Biophys. Acta*, **195**, 299 (1969).
- (346) M. I. Gulyaeva, Z. N. Bagdasarjan, S. I. Bezborodova, and S. M. Zhenodarova, *Mol. Biol. (Moscow)*, **8**, 261 (1974).
- (347) M. R. Bernfield, *J. Biol. Chem.*, **240**, 4753 (1965); **241**, 2014 (1966).
- (348) N. S. Tikhomirova-Sidorova, G. E. Ustyuzhanin, and E. M. Kogan, *Zh. Obshch. Khim.*, **38**, 1491 (1968).
- (349) E. M. Kogan, E. N. Morozova, N. S. Tikhomirova-Sidorova, and G. E. Ustyuzhanin, *Zh. Obshch. Khim.*, **39**, 2576 (1969).
- (350) A. P. Kavunenko, E. N. Morozova, and N. S. Tikhomirova-Sidorova, *Zh. Obshch. Khim.*, **41**, 226 (1971).
- (351) S. M. Zhenodarova and V. P. Klyagina, *Zh. Obshch. Khim.*, **40**, 2124 (1970).
- (352) A. P. Kavunenko, V. P. Sukharevich, and N. S. Tikhomirova-Sidorova, *Zh. Obshch. Khim.*, **41**, 679 (1971).
- (353) S. M. Zhenodarova, V. P. Klyagina, and O. A. Smolyaninova, *Zh. Obshch. Khim.*, **44**, 446 (1974).
- (354) S. M. Zhenodarova, V. P. Klyagina, O. A. Smolyaninova, E. G. Antonovich, and M. A. Prokof'ev, *Dokl. Akad. Nauk SSSR*, **217**, 221 (1974).
- (355) E. G. Antonovich, M. I. Habarova, S. M. Zhenodarova, and M. A. Prokof'ev, *Dokl. Akad. Nauk SSSR*, **200**, 1099 (1971).
- (356) M. I. Habarova and S. M. Zhenodarova, *Mol. Biol. (Moscow)*, **6**, 682 (1972).
- (357) S. M. Zhenodarova and M. I. Habarova, *Biokhimiya*, **37**, 869 (1972).
- (358) M. I. Habarova and S. M. Zhenodarova, *Zh. Obshch. Khim.*, **42**, 1655 (1972).
- (359) V. P. Klyagina, V. M. Ponomarova, and S. M. Zhenodarova, *Zh. Obshch. Khim.*, **43**, 385 (1973).
- (360) T. A. Maslennikova, E. A. Sedelnikova, V. P. Klyagina, and S. M. Zhenodarova, *Mol. Biol. (Moscow)*, **7**, 36 (1973).
- (361) S. M. Zhenodarova, E. A. Sedelnikova, M. I. Habarova, and I. B. Golovanov, *Zh. Obshch. Khim.*, **44**, 701 (1974).
- (362) E. G. Antonovich, V. M. Ponomarova, E. A. Sedelnikova, S. M. Zhenodarova, and M. A. Prokof'ev, *Dokl. Akad. Nauk SSSR*, **207**, 718 (1972).
- (363) M. I. Habarova and S. M. Zhenodarova, *Mol. Biol. (Moscow)*, **7**, 787 (1973).
- (364) O. A. Smolyaninova, E. A. Sedelnikova, and S. M. Zhenodarova, *Zh. Obshch. Khim.*, **44**, 442 (1974).
- (365) T. Koike, T. Uchida, and F. Egami, *J. Biochem. (Tokyo)*, **69**, 111 (1971).
- (366) S. Bauer, R. Lamed, and Y. Lapidot, *Biotech. Bioeng.*, **14**, 861 (1972).
- (367) H. G. Gassen and R. Nolte, *Biochem. Biophys. Res. Commun.*, **44**, 1410 (1971).
- (368) S. K. Vasilenko, A. G. Venyaminova, L. D. Detinenko, G. A. Kim, and D. G. Knorre, *Biokhimiya*, **37**, 527 (1972).
- (369) T. Ukita, Y. Takeda, and H. Hayatsu, *Chem. Pharm. Bull. (Tokyo)*, **12**, 1503 (1964).
- (370) S. A. Narang, T. M. Jacob, and H. G. Khorana, *J. Am. Chem. Soc.*, **87**, 2988 (1965).
- (371) T. M. Jacob and H. G. Khorana, *J. Am. Chem. Soc.*, **87**, 2971 (1965).
- (372) S. A. Narang and H. G. Khorana, *J. Am. Chem. Soc.*, **87**, 2981 (1965).
- (373) S. A. Narang, T. M. Jacob, and H. G. Khorana, *J. Am. Chem. Soc.*, **89**, 2158 (1967).
- (374) Yu. A. Berlin et al., *Khim. Prir. Soedin.*, **9**, 394, 402 (1973); *Chem. Abstr.*, **79**, 66724b, 66725c (1973).
- (375) C. B. Reese, J. C. M. Stewart, J. H. van Boom, H. P. M. deLeeuw, J. Nagel, and J. F. M. de Rooy, *J. Chem. Soc., Perkin Trans. 1*, 934 (1975).
- (376) B. E. Griffin and C. B. Reese, *Tetrahedron*, **24**, 2537 (1968).
- (377) B. E. Griffin and C. B. Reese, *Tetrahedron*, **25**, 4057 (1969).
- (378) E. Ohtsuka, S. Nakamura, M. Yoneda, and M. Ikehara, *Nucleic Acid Res.*, **1**, 323 (1974).
- (379) M. Ikehara, T. Nagura, and E. Ohtsuka, *Chem. Pharm. Bull.*, **22**, 123 (1974).
- (380) D. H. Rammner and H. G. Khorana, *Biochem. Biophys. Res. Commun.*, **7**, 147 (1962).
- (381) D. Soil and H. G. Khorana, *J. Am. Chem. Soc.*, **87**, 360 (1965).
- (382) F. Cramer and S. Rittner, *Tetrahedron Lett.*, 107 (1964).
- (383) R. Lohrmann, D. Soil, H. Hayatsu, E. Ohtsuka, and H. G. Khorana, *J. Am. Chem. Soc.*, **88**, 819 (1966).
- (384) E. Ohtsuka, M. Ubasawa, S. Morioka, and M. Ikehara, *J. Am. Chem. Soc.*, **95**, 4725 (1973).
- (385) S. Chladek and J. Smrt, *Collect. Czech. Chem. Commun.*, **28**, 2434 (1963).
- (386) A. Holy and K. H. Scheit, *Chem. Ber.*, **99**, 3778 (1966).
- (387) I. Gillam, S. Millward, D. Blew, M. von Tigerstrom, E. Wimmer, and G. M. Tener, *Biochemistry*, **6**, 3043 (1967).
- (388) H. Koster and W. Kaiser, *Justus Liebig's Ann. Chem.*, 336 (1974).
- (389) S. A. Narang and J. J. Michniewicz, *Anal. Biochem.*, **49**, 379 (1972).
- (390) B. Z. Egan, *Biochim. Biophys. Acta*, **220**, 245 (1973).
- (391) B. Z. Egan, *Anal. Biochem.*, **56**, 616 (1973).
- (392) C. R. Astell and M. Smith, *Biochemistry*, **11**, 4114 (1972).
- (393) C. R. Astell, M. T. Doel, P. A. Jahnke, and M. Smith, *Biochemistry*, **12**, 5068 (1973).
- (394) M. T. Doel and M. Smith, *FEBS Lett.*, **34**, 99 (1973).
- (395) S. Gillam, K. Waterman, and M. Smith, *Nucleic Acid Res.*, **2**, 625 (1975).
- (396) S. Okada, Y. Husimi, S. Tanabe, and A. Wada, *Biopolymers*, **14**, 33 (1975).
- (397) A. F. Cook, A. de Czekala, T. F. Gabriel, C. L. Harvey, M. Homan, J. E. Michaelewsky, and A. L. Nussbaum, *Biochim. Biophys. Acta*, **324**, 2956 (1965).
- (398) E. Ohtsuka, M. W. Moon, and H. G. Khorana, *J. Am. Chem. Soc.*, **87**, 2956 (1965).
- (399) J. Smrt, *Collect. Czech. Chem. Commun.*, **37**, 846 (1972).
- (400) J. Smrt, *Collect. Czech. Chem. Commun.*, **37**, 1870 (1972).
- (401) J. C. Catlin and F. Cramer, *J. Org. Chem.*, **38**, 245 (1973).
- (402) T. Neilson, *J. Chem. Soc., Chem. Commun.*, 1139 (1969).
- (403) J. Smrt, *Tetrahedron Lett.*, 3437 (1972).
- (404) J. Smrt, *Collect. Czech. Chem. Commun.*, **39**, 972 (1974).
- (405) J. Smrt, *Collect. Czech. Chem. Commun.*, **38**, 3189 (1975).
- (406) J. Smrt, *Collect. Czech. Chem. Commun.*, **40**, 1043 (1975).
- (407) A. Holy, J. Smrt, and F. Sorm, *Collect. Czech. Chem. Commun.*, **32**, 2980 (1967).
- (408) M. P. Mertes, A. Holy, and J. Smrt, *Collect. Czech. Chem. Commun.*, **33**, 3313 (1968).
- (409) K. H. Scheit, *Biochim. Biophys. Acta*, **166**, 285 (1968).
- (410) S. Irie, T. Uchida, and F. Egami, *Biochim. Biophys. Acta*, **209**, 289 (1970).
- (411) K. Miura, M. Shiga, and T. Ueda, *J. Biochem. (Tokyo)*, **73**, 1279 (1973).
- (412) M. P. Schweizer, R. Thedford, and J. Slama, *Biochim. Biophys. Acta*, **232**, 217 (1971).
- (413) A. Holy, J. Smrt, and F. Sorm, *Collect. Czech. Chem. Commun.*, **33**, 3809 (1968).
- (414) M. Ikehara, S. Uesugi, and M. Kobayashi, *Chem. Pharm. Bull.*, **20**, 3294 (1972).
- (415) H. Pischel and A. Holy, *Collect. Czech. Chem. Commun.*, **34**, 89 (1969).
- (416) I. Gregor, U. Sequin, and C. Tamm, *Helv. Chim. Acta*, **58**, 712 (1975).
- (417) W. E. Trommer, H. Wenzel, and G. Pfeleiderer, *Justus Liebig's Ann. Chem.*, 1357 (1974).
- (418) M. Ikehara and T. Tezuka, *Nucleic Acid Res.*, **1**, 479 (1974).
- (419) M. Ikehara, S. Uesugi, and J. Yano, *J. Am. Chem. Soc.*, **96**, 4966 (1974).
- (420) M. Ikehara, S. Uesugi, and M. Yasumoto, *J. Am. Chem. Soc.*, **96**, 4966 (1974).
- (421) S. Uesugi, M. Yasumoto, M. Ikehara, K. N. Fang, and P. O. P. Ts'o, *J. Am. Chem. Soc.*, **94**, 5480 (1972).
- (422) M. Ikehara, T. Nagura, and E. Ohtsuka, *Nucleic Acid Res.*, **2**, 1345 (1975).
- (423) M. Ikehara, T. Nagura, and E. Ohtsuka, *Chem. Pharm. Bull.*, **22**, 2578 (1974).
- (424) K. K. Ogilvie and D. J. Iwacha, *Can. J. Chem.*, **52**, 1787 (1974).
- (425) J. Smrt and F. Sorm, *Collect. Czech. Chem. Commun.*, **32**, 3169 (1967).
- (426) J. C. Maurizot, W. J. Wechler, J. Brahm, and C. Sadron, *Nature (London)*, **219**, 377 (1968).
- (427) U. Sequin, *Helv. Chim. Acta*, **57**, 68 (1964).
- (428) R. L. Letsinger and W. S. Mungall, *J. Org. Chem.*, **35**, 3800 (1970).
- (429) R. L. Letsinger, J. S. Wilkes, and L. B. Dumas, *J. Am. Chem. Soc.*, **94**, 292 (1972).
- (430) R. L. Letsinger and G. A. Heavner, *Tetrahedron Lett.*, 147 (1975).
- (431) G. L. Greene and R. L. Letsinger, *Nucleic Acid Res.*, **2**, 1123 (1975).
- (432) W. S. Mungall, G. L. Greene, G. A. Heavner, and R. L. Letsinger, *J. Org. Chem.*, **40**, 1659 (1975).
- (433) A. Malkiewicz and J. Smrt, *Collect. Czech. Chem. Commun.*, **38**, 2953 (1973).
- (434) J. Smrt and F. Cramer, *Collect. Czech. Chem. Commun.*, **35**, 1456 (1970).
- (435) J. Smrt and A. Malkiewicz, *Collect. Czech. Chem. Commun.*, **38**, 2962 (1973).
- (436) A. Malkiewicz and J. Smrt, *Tetrahedron Lett.*, 491 (1973).
- (437) J. Kresse, K. L. Nagpal, J. Nagyvary, and J. T. Uchic, *Nucleic Acid Res.*, **2**, 1 (1975).
- (438) A. Hodgson and A. S. Jones, *Tetrahedron Lett.*, 5349 (1972).
- (439) M. J. Gait, A. S. Jones, and R. T. Walker, *J. Chem. Soc., Perkin Trans. 1*, 1684 (1972).
- (440) E. J. Norman and J. Nagyvary, *J. Med. Chem.*, **17**, 473 (1974).
- (441) F. Cramer and G. Weimann, *Chem. Ber.*, **94**, 996 (1961).
- (442) H. Koster and W. Heidmann, *Angew. Chem., Int. Ed. Engl.*, **12**, 859 (1973).
- (443) J. Smrt, *Collect. Czech. Chem. Commun.*, **38**, 3642 (1973).
- (444) T. Neilson, K. V. Deugau, T. E. England, and E. S. Werstiuk, *Can. J. Chem.*, **53**, 1093 (1975).
- (445) H. Schaller and H. G. Khorana, *J. Am. Chem. Soc.*, **85**, 3841 (1963).
- (446) H. Kossel, M. W. Moon, and H. G. Khorana, *J. Am. Chem. Soc.*, **89**, 2148 (1967).
- (447) H. Kossel, H. Buchi, and H. G. Khorana, *J. Am. Chem. Soc.*, **89**, 2185 (1967).
- (448) A. Kumar and H. G. Khorana, *J. Am. Chem. Soc.*, **91**, 2743 (1969).
- (449) J. Hachmann and H. G. Khorana, *J. Am. Chem. Soc.*, **91**, 2749 (1969).
- (450) V. D. Smirnov, M. G. Ivanovskaya, E. V. Iliina, Z. A. Shabarova, and M. A. Prokof'ev, *Dokl. Akad. Nauk SSSR*, **206**, 1133 (1972).
- (451) V. N. Kagrananov, V. D. Smirnov, Z. A. Bogdarov, Z. A. Shabarova, and M. A. Prokof'ev, *Dokl. Akad. Nauk SSSR*, **208**, 858 (1973).
- (452) Yu. A. Berlin et al., *Khim. Prir. Soedin.*, **9**, 402 (1973).
- (453) E. A. Pyaivinen, *Zh. Obshch. Khim.*, **45**, 1170 (1975).
- (454) H. Schott and H. Kossel, *J. Am. Chem. Soc.*, **95**, 3778 (1973).
- (455) S. A. Narang, S. K. Dheer, and J. J. Michniewicz, *J. Am. Chem. Soc.*, **90**, 2702 (1968).
- (456) S. A. Narang, J. J. Michniewicz, and S. K. Dheer, *J. Am. Chem. Soc.*, **91**, 396 (1969).
- (457) S. A. Narang and S. K. Dheer, *Biochemistry*, **8**, 3443 (1969).
- (458) S. A. Narang, K. Itakura, C. P. Bahl, and Y. Y. Wigfield, *Biochem. Biophys. Res. Commun.*, **49**, 445 (1972).
- (459) S. A. Narang, K. Itakura, C. P. Bahl, and N. Katagiri, *J. Am. Chem. Soc.*,

- 96, 7074 (1974).
- (461) A. Kumar, E. Ohtsuka, and H. G. Khorana, *J. Mol. Biol.*, **72**, 289 (1972).
- (462) E. Ohtsuka, A. Kumar, and H. G. Khorana, *J. Mol. Biol.*, **72**, 309 (1972).
- (463) A. Kumar and H. G. Khorana, *J. Mol. Biol.*, **72**, 329 (1972).
- (464) K. L. Agarwal, A. Kumar, and H. G. Khorana, *J. Mol. Biol.*, **72**, 351 (1972).
- (465) M. H. Caruthers, J. H. van de Sande, and H. G. Khorana, *J. Mol. Biol.*, **72**, 375 (1972).
- (466) M. H. Caruthers and H. G. Khorana, *J. Mol. Biol.*, **72**, 407 (1972).
- (467) H. Schott, *Makromol. Chem.*, **175**, 1683 (1974).
- (468) R. B. Merrifield, *Advan. Enzymol.*, **32**, 221 (1969).
- (469) R. C. Pless and R. L. Letsinger, *Nucleic Acid Res.*, **2**, 773 (1975).
- (470) V. K. Potapov, O. G. Chekhmakhcheva, Z. A. Shabarova, and M. A. Prokof'ev, *Dokl. Akad. Nauk SSR*, **196**, 360 (1971).
- (471) W. Freist and F. Cramer, *Angew. Chem., Int. Ed. Engl.*, **9**, 368 (1970).
- (472) R. L. Letsinger and V. Mahadevan, *J. Am. Chem. Soc.*, **87**, 3526 (1965).
- (473) R. L. Letsinger and V. Mahadevan, *J. Am. Chem. Soc.*, **88**, 5319 (1966).
- (474) V. K. Potapov, M. N. Kochetkova, and Z. A. Shabarova, *Zh. Obshch. Khim.*, **41**, 240 (1971).
- (475) H. Schott, F. Brandstetter, and E. Bayer, *Makromol. Chem.*, **173**, 247 (1973).
- (476) P. T. Gilham, *Biochemistry*, **7**, 2809 (1968).
- (477) H. Sommer and F. Cramer, *Angew. Chem., Int. Ed. Engl.*, **11**, 717 (1972).
- (478) R. L. Letsinger and M. J. Kornet, *J. Am. Chem. Soc.*, **85**, 3045 (1963).
- (479) R. L. Letsinger, M. J. Kornet, V. Mahadevan, and D. M. Jerina, *J. Am. Chem. Soc.*, **86**, 5163 (1964).
- (480) L. R. Melby and D. R. Strobach, *J. Am. Chem. Soc.*, **89**, 450 (1967).
- (481) L. R. Melby and D. R. Strobach, *J. Org. Chem.*, **34**, 421, 427 (1969).
- (482) H. Koster and F. Cramer, *Justus Liebig's Ann. Chem.*, **766**, 6 (1972).
- (483) G. M. Blackburn, M. J. Brown, and M. R. Harris, *Chem. Commun.*, 611 (1966).
- (484) G. M. Blackburn, M. J. Brown, and M. R. Harris, *J. Chem. Soc. C*, 2438 (1967).
- (485) V. F. Zarytova, V. K. Potapov, Z. A. Shabarova, and D. G. Knorre, *Dokl. Akad. Nauk SSSR*, **199**, 1072 (1971).
- (486) R. L. Letsinger, M. H. Caruthers, and D. M. Jerina, *Biochemistry*, **6**, 1379 (1967).
- (487) T. Shimadzu and R. L. Letsinger, *J. Org. Chem.*, **33**, 708 (1968).
- (488) T. Shimadzu and R. L. Letsinger, *Bull. Chem. Soc. Jpn.*, **44**, 1673 (1971).
- (489) F. Cramer and H. Koster, *Angew. Chem., Int. Ed. Engl.*, **7**, 473 (1968).
- (490) M. M. Kabachnik, N. G. Timofeeva, M. V. Budanov, V. K. Potapov, Z. A. Shabarova, and M. A. Prokof'ev, *Zh. Obshch. Khim.*, **43**, 379 (1973).
- (491) H. Koster and S. Geussenhainer, *Angew. Chem., Int. Ed. Engl.*, **11**, 713 (1972).
- (492) H. Koster and F. Cramer, *Makromol. Chem.*, **167**, 171 (1973).
- (493) H. Koster and F. Cramer, *Justus Liebig's Ann. Chem.*, **1974**, 946.
- (494) H. Koster, A. Pollack, and F. Cramer, *Justus Liebig's Ann. Chem.*, **1974**, 959.
- (495) R. Glaser, U. Sequin, and C. Tamm, *Helv. Chim. Acta*, **56**, 654 (1973).
- (496) H. Hayatsu and H. G. Khorana, *J. Am. Chem. Soc.*, **88**, 3181 (1966); **89**, 3880 (1967).
- (497) F. Cramer, R. Helbig, H. Hettler, K. H. Scheit, and H. Seliger, *Angew. Chem., Int. Ed. Engl.*, **5**, 601 (1966).
- (498) H. Koster, *Tetrahedron Lett.*, 1535 (1972).
- (499) T. Seita, K. Yamauchi, M. Kinoshita, and M. Imoto, *Makromol. Chem.*, **164**, 15 (1973).
- (500) H. Seliger and G. Aumann, *Makromol. Chem.*, **176**, 609 (1975).
- (501) F. Brandstetter, H. Schott, and E. Bayer, *Tetrahedron Lett.*, 2997 (1973).
- (502) H. Schott, *Angew. Chem., Int. Ed. Engl.*, **12**, 246 (1973).
- (503) H. Koster, *Tetrahedron Lett.*, 1527 (1972).
- (504) H. Koster and K. Heyns, *Tetrahedron Lett.*, 1531 (1972).
- (505) T. M. Chapman and D. G. Kleid, *J. Chem. Soc., Chem. Commun.*, 193 (1973).
- (506) F. Brandstetter, H. Schott, and E. Bayer, *Tetrahedron Lett.*, 2705 (1974).
- (507) H. Seliger, *Makromol. Chem.*, **176**, 1611 (1975).
- (508) G. DeBoer and P. O. P. Ts'o, *Biochemistry*, **13**, 2638 (1974).
- (509) H. Sommer and F. Cramer, *Chem. Ber.*, **107**, 24 (1974).
- (510) V. V. Nosova et al., *Dokl. Akad. Nauk SSSR*, **219**, 1134 (1974).
- (511) E. Ohtsuka, S. Morioka, and M. Ikehara, *J. Am. Chem. Soc.*, **94**, 3229 (1972).
- (512) D. H. Rich and S. K. Gurwara, *J. Am. Chem. Soc.*, **97**, 1575 (1975).
- (513) E. Bayer, H. Eckstein, K. Hagele, W. A. Konig, W. Brunning, H. Hagenmaier, and W. Parr, *J. Am. Chem. Soc.*, **92**, 1735 (1970).
- (514) K. K. Ogilvie and K. Kroeker, *Can. J. Chem.*, **50**, 1211 (1972).
- (515) G. J. Powers, R. L. Jones, G. A. Randall, M. H. Caruthers, J. H. van de Sande, and H. G. Khorana, *J. Am. Chem. Soc.*, **97**, 875 (1975).
- (516) A. V. Nikolaev, S. I. Turkin, V. K. Potopov, and Z. A. Shabarova, *Bioorg. Khim.*, **1**, 1236 (1975).
- (517) K. L. Agarwal, Y. A. Berlin, H.-J. Fritz, M. J. Gait, D. G. Kleid, R. G. Lees, K. E. Norris, B. Ramamoorthy, and H. G. Khorana, *J. Am. Chem. Soc.*, **98**, 1065 (1976).
- (518) H. Takaku, Y. Shimada, and T. Hata, *Chem. Lett.*, **873** (1975).
- (519) Y. A. Berlin, M. N. Kolosov, and O. G. Chakhmakhcheva, *Bioorg. Khim.*, **1**, 1733 (1975).
- (520) E. Ohtsuka, T. Miyake, and M. Ikehara, *Nucleic Acid Res.*, **3**, 653 (1976).
- (521) N. Katagiri, K. Itakura, and S. A. Narang, *J. Am. Chem. Soc.*, **97**, 7332 (1975).
- (522) H. Takaku, Y. Shimada, Y. Nakajima, and T. Hata, *Nucleic Acid Res.*, **3**, 1233 (1976).
- (523) M. Rubinstein and A. Patchornik, *Tetrahedron*, **31**, 1517 (1975).
- (524) Y. A. Berlin et al., *Bioorg. Khim.*, **1**, 1121 (1975).
- (525) J. Stawinski, T. Hozumi, and S. A. Narang, *Can. J. Chem.*, **54**, 670 (1976).
- (526) R. L. Letsinger and W. B. Lunsford, *J. Am. Chem. Soc.*, **98**, 3655 (1976).
- (527) P. W. Johnson, R. von Tigerstrom, and M. Smith, *Nucleic Acid Res.*, **2**, 1745 (1975).
- (528) R. von Tigerstrom, P. Jahnke, and M. Smith, *Nucleic Acid Res.*, **2**, 1727 (1975).
- (529) R. von Tigerstrom, P. Jahnke, V. Wylie, and M. Smith, *Nucleic Acid Res.*, **2**, 1737 (1975).
- (530) M. Rubinstein and A. Patchornik, *Tetrahedron*, **31**, 2107 (1975).
- (531) J. H. van Boom, P. M. J. Burgers, and P. H. van Deursen, *Tetrahedron Lett.*, 869 (1976).
- (532) Y. Mizuno, S. Kitano, and A. Nomura, *Nucleic Acid Res.*, **2**, 2193 (1975).
- (533) H. Seliger, H. Schutz, and M. Philipp, *Makromol. Chem.*, **176**, 2943 (1975).
- (533a) H. Seliger, et al., *Makromol. Chem.*, **176**, 3127 (1975).
- (533b) H. Seliger, E. Rossner, G. Aumann, V. Genrich, M. Holupirek, T. Knable, and M. Philipp, *Makromol. Chem.*, **176**, 2915 (1975).
- (534) S. Uesugi, T. Tezuka, and M. Ikehara, *J. Am. Chem. Soc.*, **98**, 969 (1976).
- (535) M. Ikehara and T. Tezuka, *Nucleic Acid Res.*, **2**, 1539 (1975).
- (536) D. G. Odom and J. T. Brady, *J. Mol. Evol.*, **8**, 199 (1975).
- (537) D. G. Odom, J. T. Brady, and J. Oro, *J. Mol. Evol.*, **7**, 151 (1976).
- (538) D. A. Usher and A. H. McHale, *Science*, **192**, 53 (1976).
- (539) R. L. Ratliff, D. E. Hoard, F. N. Hayes, D. A. Smith, and D. M. Gray, *Biochemistry*, **15**, 168 (1976).
- (540) R. Lohrmann and L. E. Orgel, *Nature (London)*, **261**, 342 (1976).
- (541) Y. A. Berlin et al., *Bioorg. Khim.*, **1**, 1113 (1975).
- (542) G. T. Asteriadis, M. A. Armbruster, and P. T. Gilham, *Anal. Biochem.*, **70**, 64 (1976).
- (543) F. D. Smirnov, K. I. Ratmanova, Z. A. Shabarova, and M. A. Prokof'ev, *Dokl. Akad. Nauk SSSR*, **223**, 1153 (1975).
- (544) M. Ikehara, *Ann. N.Y. Acad. Sci.*, **255**, 71 (1975).
- (545) H. Schott, *J. Chromatogr.*, **115**, 461 (1975).
- (546) E. Ohtsuka, K. Fujiyama, M. Ohashi, and M. Ikehara, *Chem. Pharm. Bull.*, **24**, 570 (1976).
- (547) S. N. Mikhailov and J. Smrt, *Collect. Czech. Chem. Commun.*, **40**, 2353, 3739 (1975).
- (548) K. Golankiewicz and A. Jankowski, *Nucleic Acid Res.*, **3**, 709 (1976).
- (549) J. H. van Boom, P. M. J. Burgers, P. H. van Deursen, J. F. M. de Rooy, and C. B. Reese, *J. Chem. Soc., Chem. Commun.*, 167 (1976).
- (550) T. E. England and T. Neilson, *Can. J. Chem.*, **54**, 1714 (1976).
- (551) K. Itakura, N. Katagiri, C. P. Bahl, R. H. Wightman, and S. A. Narang, *J. Am. Chem. Soc.*, **97**, 7327 (1975).
- (552) H. G. Khorana, K. L. Agarwal, P. Besmer, H. Buchi, M. H. Caruthers, P. J. Cashion, M. Fridkin, E. Jay, K. Kleppe, R. Kleppe, A. Kumar, P. C. Loewen, R. C. Miller, K. Minamoto, A. Panet, U. L. Rajbhandary, B. Ramamoorthy, T. Sekiya, T. Takeya, and J. H. van de Sande, *J. Biol. Chem.*, **251**, 565 (1976), and the following 11 papers.
- (553) K. Itakura et al., *J. Biol. Chem.*, **250**, 4592 (1975).
- (554) Y. Berlin et al., *Bioorg. Khim.*, **1**, 1738 (1975), **2**, 166 (1976).
- (555) C. L. Harvey, K. Olsen, A. de Czekala, and A. L. Nussbaum, *Nucleic Acid Res.*, **2**, 2007 (1975).
- (556) S. M. Zhenodarova and V. P. Klyagina, *Bioorg. Khim.*, **1**, 769 (1975).
- (557) E. Ohtsuka, S. Nishikawa, M. Sugiura, and M. Ikehara, *Nucleic Acid Res.*, **3**, 1613 (1976).
- (558) Y. A. Berlin, M. N. Kolosov, V. G. Korobko, O. G. Chakhmakhcheva, and L. N. Shingarova, *Bioorg. Khim.*, **2**, 773 (1976).
- (559) H. Koster, H. Blocker, R. Frank, S. Geussenhainer, W. Kaiser, and Z. Hoppe-Seyler's, *Z. Physiol. Chem.*, **356**, 1585 (1975).
- (560) Y. A. Berlin et al., *Bioorg. Khim.*, **2**, 773 (1976).
- (561) M. M. Gusenkova and B. I. Sukhorukov, *J. Gen. Chem.*, **46**, 939 (1976).
- (562) U. V. Tumanov, M. G. Shlapnikov, V. K. Potopov, and Z. A. Shabarova, *Bioorg. Khim.*, **1**, 1291 (1975).
- (563) F. Brandstetter, H. Schott, and E. Bayer, *Makromol. Chem.*, **176**, 2163 (1975).
- (564) R. J. Zhadanov and S. M. Zhenodarova, *Synthesis*, 222 (1975).
- (565) H. Kössel and H. Seliger, *Fortschr. Chem. Org. Naturst.*, **32**, 297 (1975).